



**CPS SCA Series Grid-tied PV Inverter
CPS SCA25KTL-DO/US-208
CPS SCA50KTL-DO/US-480
And SCA60KTL-DO/US-480**

Installation and Operation Manual - Rev3.4



CHINT POWER SYSTEMS AMERICA CO.

Revision 3.4 - May 2020

Revision History			
Rev Number	Chap/Sec	Rev Date	Description
1.0	N/A	Aug 2016	Initial Release
2.0	3	Sep 2016	H4 Wirebox, Operating Mode
2.1	3	Feb 2017	H4 Termination, AC Terminal
2.2	3, 5, 7, 8	Sept 2017	AC Terminal, Parameters, Trouble-Shooting, Accessories
3.0	3, 5, 6, 10	Feb 2018	Increased kVA Ratings
3.1	3 5 3.3 9.3	Mar 2019	Allow MPPT to be Unbalanced Increased RS485 3pin Terminal LCD interface Parameters Y-Comb Terminal
3.2	2, 3	Oct 2019	Added Rapid Shutdown Wirebox Removed H4 Wirebox Added water tight design/installation requirements
3.3	1 3 3.2.2 3.2.4 3.3.3	Mar 2020	Add disclaimer 1) Update packing list 2) Wiring box bottom seal has been cancelled. Installation method pictures Add Remark& Label Change DC terminal description In the DC fuse description, Change

	<p>3.3.5</p> <p>3.4.1</p> <p>6</p> <p>10.1</p> <p>10.3.3</p>		<p>Sinofuse into Busmann.</p> <p>Change AC terminal description.</p> <p>Delete wiring box bottom seal description.</p> <p>Modify the communication board description.</p> <p>Add ISO-NE regulation</p> <p>Update partial settings</p> <p>Update datasheet</p> <p>Update 10.3.3 chapter curve and description</p>
3.4		<p>August 2020</p>	<p>Add CPS SCA25KTL-DO/US-208 model description.</p>



Table of Contents

BEFORE YOU START...	1
1 IMPORTANT SAFETY INSTRUCTIONS	3
2 OVERVIEW	8
2.1 INVERTER FOR GRID-TIED PV SYSTEMS	8
2.2 PRODUCT FEATURES	8
2.3 PRODUCT PROTECTION AND FUNCTIONS	10
2.4 SMART INVERTER FUNCTIONS (DEFAULT STATE):	10
2.5 APPEARANCE AND MAIN ITEM DESCRIPTION	11
2.6 SCHEMATIC DIAGRAM AND CIRCUIT DESIGN	12
2.7 ANTI-ISLANDING DETECTION	15
2.8 DC GROUND FAULT PROTECTION	15
2.9 SURGE SUPPRESSION	15
2.10 DC ARC-FAULT PROTECTION	16
2.11 MODULE-LEVEL RAPID SHUTDOWN	16
3 INSTALLATION	17
3.1 RECOMMENDATIONS BEFORE INSTALLATION	19
3.2 MECHANICAL INSTALLATION	22
3.2.1 <i>Dimensions</i>	22
3.2.2 <i>Installation Method (see Figure 3-2)</i>	22
3.2.3 <i>Installation Space Requirement</i>	24
3.2.4 <i>Mounting the Inverter onto the Bracket</i>	28
3.3 ELECTRICAL INSTALLATION	36
3.3.1 <i>Removing/Replacing the Wiring Box Cover:</i>	36
3.3.2 <i>Wiring Boxes</i>	38
3.3.3 <i>DC Connection</i>	40

3.3.4	<i>AC and Ground Connection</i>	50
3.3.5	<i>AC Connections</i>	53
3.4	COMMUNICATION CONNECTION	58
3.4.1	<i>Description of the Communication Board</i>	59
3.4.2	<i>RS485 Communication</i>	59
3.4.3	<i>RS485 Network Set-up</i>	60
3.4.4	<i>Communication Wiring</i>	62
4	USER INTERFACE	63
4.1	DESCRIPTION OF LCD PANEL.....	63
4.2	OPERATION STATE.....	65
4.3	INTERFACE TYPES.....	66
5	COMMISSIONING	68
5.1	MECHANICAL INSTALLATION CHECK	68
5.2	CONDUCTOR CONNECTIONS CHECK	68
5.3	ELECTRICAL CHECK.....	68
5.4	COMMISSIONING STEPS	69
6	MAIN MENU AND OPERATION	75
6.1	MEASUREMENT DATA.....	75
6.2	SETTING.....	76
6.2.1	<i>System Parameters</i>	78
6.2.2	<i>Control Command</i>	80
6.2.3	<i>Protect Parameters</i>	84
6.2.4	<i>LVRT/HVRT Parameters</i>	92
6.2.5	<i>Power Derating Setup</i>	99
6.2.6	<i>Reactive Power Derating Setup</i>	103
6.2.7	<i>Arc Parameters</i>	110
6.2.8	<i>Other Parameters</i>	110



6.3	POWER ON/OFF	120
6.3.1	<i>Manual Power ON/OFF</i>	120
6.3.2	<i>Automatic Turn ON/OFF</i>	120
6.4	HISTORY RECORD	120
6.5	DEVICE INFORMATION.....	121
6.6	START-UP.....	122
6.7	SHUT-DOWN	123
6.8	OPERATION MODE	123
6.9	GRID-TIED POWER GENERATION	124
6.10	FIRMWARE UPGRADE.....	124
7	FAULT SHUTDOWN AND TROUBLESHOOTING	127
7.1	LED FAULT AND TROUBLESHOOTING	127
7.2	LCD FAULT AND TROUBLESHOOTING.....	128
8	MAINTENANCE AND DE-INSTALLATION	134
8.1	PRODUCT MAINTENANCE	134
8.1.1	<i>Check Electrical Connections</i>	134
8.1.2	<i>Clean the Air Vent Grate</i>	134
8.1.3	<i>Replace the Cooling Fans</i>	134
8.1.4	<i>Replace the Inverter</i>	137
8.2	DE-INSTALLING THE INVERTER.....	139
9	ACCESSORIES	141
9.1	FUSE BYPASS TERMINALS.....	141
9.1.1	<i>Bypass Input Terminal Instructions</i>	141
9.2	SHADE COVER (SSC-60ST)	143
9.2.1	<i>Protection from Harsh Conditions</i>	143
9.2.2	<i>Increased Energy Production</i>	143
9.3	Y-COMB TERMINAL BLOCK (OPTIONAL)	144

10	TECHNICAL DATA	145
10.1	DATASHEET	145
10.2	MEASUREMENT TOLERANCES	148
10.3	PRODUCTION GRAPHS	149
10.3.1	<i>High Temperature Derating Graph.....</i>	<i>149</i>
10.3.2	<i>Altitude Derating Graph.....</i>	<i>150</i>
10.3.3	<i>Grid Voltage Derating Graph.....</i>	<i>151</i>
10.3.4	<i>Reactive Power Capability.....</i>	<i>153</i>
11	LIMITED WARRANTY	154



Before You Start...

Scope

This Installation and Operation manual contains important information, safety guidelines, detailed planning and setup information for installation, as well as information about configuring, operating and troubleshooting the CPS SCA 25 KTL-DO/US-208, CPS SCA50KTL-DO/US-480 and CPS SCA 60KTL-DO /US-480 3-Phase String Inverters. Here after in this manual this equipment may be referred to simply as the inverters. Be sure to read this manual carefully before operating or servicing the inverters.

Audience

The information in Chapters 1 “Overview”, 4 “User Interface”, 6 “Main Menu and Operation”, 7 “Faut Shutdown and troubleshooting”, and 9 “Accessories” is intended for the owner and operator of the inverter, and does not require any special training or qualifications. The information in Chapters 0 “Installation”, 5 “Commisionning”, 8 “Maintenance and De-installation” is intended for qualified personnel only. Qualified personnel have training, knowledge, and experience in:

- Installing electrical equipment and PV power systems (up to 1000VDC).
- Applying all local installation codes.
 - Analyzing and eliminating the hazards involved in performing electrical work.
 - Selecting and using Personal Protective Equipment (PPE).



Installation, commissioning, troubleshooting, and maintenance of the inverter must be done only by qualified personnel.

Thank you for choosing a CPS SCA 25 KTL-DO/US-208、CPS SCA 50KTL-DO/US-480 or CPS SCA60KTL-DO/US-480 3-Phase String Inverter. These PV Inverters are high performance and highly reliable products specifically designed for the North American Solar market.

Instructions inside this user manual will help you solve most installation and operation difficulties. Installation, commissioning, troubleshooting, and maintenance of the inverter must be performed by qualified personnel. If you encounter any problems during installation or operation of this unit, first check the user manual before contacting CPS Customer Service. This user manual is applicable for the following models:

CPS SCA 25 KTL-DO/US-208、CPS SCA50KTL-DO/US-480 and CPS SCA60KTL-DO/US-480

Please keep this user manual on hand for quick reference.

The manual will be periodically updated or revised due to the product development or improvement. The latest version of this manual can be acquired via the website at www.chintpowersystems.com.





1 Important Safety Instructions

(SAVE THESE INSTRUCTIONS)



Please read this user manual carefully before installation of the inverter. CPS reserves the right to refuse warranty claims for equipment damage if the user fails to install the product according to the instructions in this manual.

Failure to follow these instructions and other relevant safety procedures may result in voiding of the warranty and/or damage to the inverter or other property!





Warnings and symbols in this document

	DANGER: DANGER indicates a hazardous situation which, if not avoided, will result in death or serious injury.
	WARNING: WARNING indicates a hazardous situation which, if not avoided, could result in death or serious injury.
	CAUTION: CAUTION indicates a hazardous situation which, if not avoided, could result in minor or moderate injury.
	NOTICE: NOTICE indicates a hazardous situation which, if not avoided, could result in the inverter working abnormally or property loss.
	INSTRUCTION: INSTRUCTION indicates important supplementary information or provides skills or tips that can be used to help you solve a problem or save you time.

Warnings and Markings on the product

	<p>CAUTION:</p> <p>Risk of electric shock from energy stored in capacitor.</p> <p>Do not remove cover until 5 minutes after disconnecting all sources of supply.</p> <p>CAUTION:</p> <p>Risk of electric shock, do not remove cover. No user serviceable parts inside. Refer servicing to qualified service personnel.</p> <p>WARNING:</p> <p>Electric shock hazard. The DC conductors of this photovoltaic system are ungrounded and may be energized.</p> <p>CAUTION:</p> <p>Risk of Electric Shock.</p> <p>a) Both ac and dc voltage sources are terminated inside this equipment. Each circuit must be individually disconnected before servicing.</p> <p>b) When the photovoltaic array is exposed to light, it supplies a dc voltage to this equipment.</p> <p>WARNING:</p> <p>Electric Shock Hazard.</p> <p>The DC conductors of this photovoltaic system are normally ungrounded but will become intermittently grounded without indication when the inverter measures the PV array isolation.</p>
	<p>CAUTION:</p> <p>Hot surfaces. To reduce the risk of burns. Do not touch.</p>

Warnings and Markings on the product (cont'd)

	<p>WARNING:</p> <p>For continued protection against risk of fire, replace only with same type and ratings of fuse.</p>
	<p>WARNING:</p> <p>HAZARDOUS VOLTAGE AREA UNDER THE PLASTIC COVER.</p> <p>DO NOT OPEN FUSE HOLDERS UNDER LOAD!</p> <p>PERSONAL PROTECTIVE EQUIPMENT MUST BE USED/WORN BEFORE ACCESSING FUSES!</p> <p>DO NOT OPEN FUSE HOLDERS IF BYPASS TERMINALS ARE INSTALLED!</p>
	<p>WARNING:</p> <p>High touch current.</p> <p>Earth connection essential before connecting supply.</p>
	<p>INFORMATION:</p> <p>For more details please see the user manual.</p>

**WARNING:**

All the installation and wiring connections must be performed by qualified technical personnel. Disconnect the inverter from the PV modules and the AC grid before maintaining or servicing the equipment.

Risk of electric shock and fire. Use only with PV modules that have a maximum system voltage of rating of 1000V_{DC} or higher.

Electric shock Hazard. The DC conductors of this photovoltaic system are normally ungrounded but will become intermittently grounded without indication when the inverter performs the PV array isolation measurement.

Shock Hazard. The inverter is energized from both AC and DC sources. Disconnect all energy sources before servicing.

For continued protection against risk of fire, replace only with same type and ratings of fuse.

**DANGER:**

Disconnect the inverter from the AC grid and PV modules before removing covers or opening the equipment. Wait at least 5 minutes after disconnecting from the DC and AC sources before servicing or maintaining the inverter. Ensure hazardous high voltage and energy inside the inverter has been discharged prior to servicing.

**NOTICE:**

The inverters are designed to only interconnect with an AC power source as part of the public electric utility grid. Do not connect the AC output of the inverters directly to any private electric utility power equipment. The inverters are to be installed with floating or ungrounded PV arrays only.



CAUTION:

CPS SCA 25 KTL-DO/US-208, CPS SCA50KTL-DO/US-480 and SCA60KTL-DO/US-480 inverters weigh approximately **56kg (123.5 pounds)**. The wirebox portion weighs approximately **15kg (33 pounds)**.

Ensure the mounting bracket is properly installed before hanging the inverter and wirebox on the bracket. A team of two is recommended to lift and place the inverter and wirebox into position.



INSTRUCTION:

Please check with your local electric utility supply company before selecting a grid standard. If the inverter is operated with an incorrect grid standard, the electric utility supply company may cancel the interconnection agreement.

Placing the inverter into operation before the overall system complies with the national codes, rules and safety regulations of the application is also not permitted.



WARNING:**WARNING**

This product can expose you to chemicals including lead, known to the state of California to cause cancer and birth defects or other reproductive harm. For more information, go to www.P65Warnings.ca.gov

2 Overview

2.1 Inverter for grid-tied PV systems

CPS SCA 25 KTL-DO/US-208, CPS SCA50KTL-DO/US-480 and SCA60 KTL- DO/US-480 3-Phase Transformerless String Inverters are designed for use with an UNGROUNDED PV array in carport, commercial rooftop, and large utility scale PV grid-tied systems. The system is generally made up of PV modules, a 3-Phase String Inverter with a fused combiner/disconnect, and AC power distribution equipment (Figure 2-1). The inverter converts the available DC energy from the PV modules to AC power by synchronizing the output current to the same frequency and phase as the AC grid. All or part of the AC power is supplied to local loads, and the surplus power is exported to the electric utility grid.

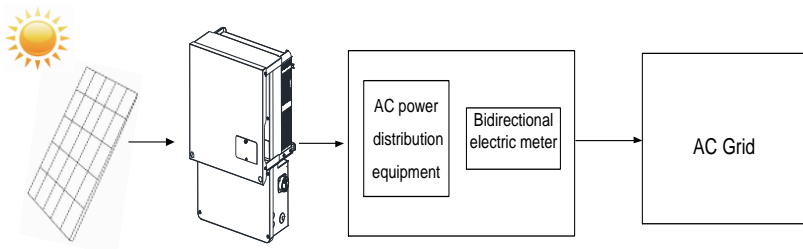

Figure 2-1: Grid-tied PV System

2.2 Product Features

- **High Conversion Efficiency:** Advanced 3-level conversion topology with Space-Vector PWM; SCA25KTL-DO/US-208 Max. efficiency: 97%, CEC efficiency: 96.5%. SCA50/60KTL-DO/US-480 Max. efficiency: 98.8%, CEC efficiency: 98.5%.



- **Grid Adaptability:** IEEE 1547 Interconnect Standard and CPUC Rule 21 applicable; Reactive Power; >0.99 PF (± 0.8 adjustable), Selectable Apparent Power rating enables Full Active Power rating to ± 0.91 PF, and optional local or remote Active Power Curtailment.
- **Flexible Communication:** Supports standard CPS Modbus RS485, SunSpec Modbus, and HTTPS/XML communications via Flex Gateway to ensure compatibility with 3rd party monitoring and control systems. The Flex Gateway card enables further command/control as well as remote firmware upgrades. (Flex Gateway card is optional accessory. Refer to Flex Gateway manual for further detailed information.)
- **Wide DC input voltage range:** Operating DC Input Voltage Range: 200-950VDC; Max DC input voltage: 1000VDC.
- **Long Service Life:** Designed with thin-film capacitors to extend inverter's service life.
- **3 MPPTs:** Multi-channel MPPT (Maximum Power Point Tracker) enables maximum design flexibility and energy harvest optimization over the life of the system.
- **Separable Wirebox:** The wirebox enables fused input of either discrete wiring using the Standard wirebox, SCA50/60KTL-DO/US-480 optional rapid shutdown wirebox with integrated Sunspec PLC transmitter for use with APS, TS4-F integrated smart modules and APS, Tigo TS4-A-F products, SCA25KTL-DO/US-208 have rapid shutdown wirebox with integrated Sunspec PLC transmitter for use with APS smart modules and APS products.
- **High Protection Degree:** Powder coated aluminum NEMA 4X enclosure meets the demanding needs of both indoor and outdoor use.
- **Intelligent Integration:** Integrated DC/AC disconnect switches, and up to 15 fused string inputs eliminate the need for external DC combiner

boxes, simplifying installation and the need for DC BOS equipment. The rapid shutdown version wirebox has integrated the rapid shutdown PLC transmitter, requiring no field wiring, and eliminated the negative DC fuses in accordance with the 2017 National Electric Code.

2.3 Product Protection and Functions

- ✓ AC output voltage and frequency monitoring
- ✓ Anti-islanding detection with bi-directional frequency perturbation
- ✓ DC input and AC output over-voltage protection
- ✓ DC input and AC output over-current protection
- ✓ DC input insulation to ground monitoring
- ✓ DC injection of AC output
- ✓ DC Arc-fault detection and circuit interruption
- ✓ Leakage current to ground monitoring
- ✓ Internal enclosure temperature monitoring
- ✓ IGBT power module temperature monitoring
- ✓ KVA overhead to produce rated Active Power at 0.91 power factor
- ✓ Load rejection over voltage (LROV) protection
- ✓ No neutral connection required - delta connection permitted with external AC GFCI
- ✓ PVRSS certified rapid shutdown compliant to 2017 NEC (RSD version only).

2.4 Smart Inverter Functions (default state):

- ✓ Anti-Islanding – activated
- ✓ Low/High Voltage Ride-Through – activated
- ✓ Low/High Frequency Ride-Through – activated
- ✓ Dynamic Volt/VAR Operations – activated
- ✓ Ramp Rates – activated

- ✓ Fixed Power Factor – deactivated
- ✓ Reconnect by “Soft-Start” Methods – activated
- ✓ Frequency-Watt – activated
- ✓ Volt-Watt – activated
- ✓ Set Active Power Function Mode (Optional) – activated under mutual agreement
- ✓ Dynamic Reactive Power Support Mode (Optional) – activated under mutual agreement

2.5 Appearance and Main Item Description

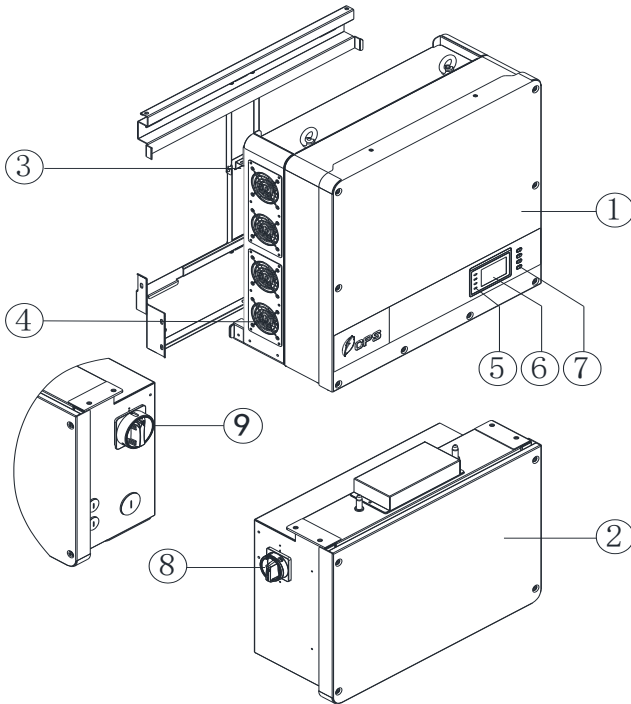

Figure 2-2 Diagram of the Inverter Assembly

Main Items of the Inverter:

- ① Main inverter enclosure
- ② Inverter wirebox
- ③ Inverter mounting bracket
- ④ Cooling fans
- ⑤ LED indicator lights
- ⑥ User LCD display
- ⑦ User Key buttons
- ⑧ DC switch: DC power on/off
- ⑨ AC switch: AC power on/off

2.6 Schematic Diagram and Circuit Design

The basic electrical schematic diagram of the CPS SCA50/60KTL-DO/US-480、CPS SCA 25 KTL-DO/US-208 3-Phase String Inverters are shown in Figure 2- 、Figure 2- and Figure 2-. The input from PV source circuits passes through surge protection circuitry, DC EMI wave filters, and independent DC-DC boost circuitry to achieve maximum power point tracking and boost the voltages to a common DC bus. The inverter uses line voltage and frequency measurements to synchronize to the grid and converts the available PV energy to AC power by injecting balanced 3-phase AC current into the electric utility grid. Any high frequency AC component is removed by passing through a two-stage relay and EMI wave filter to produce high quality AC power.

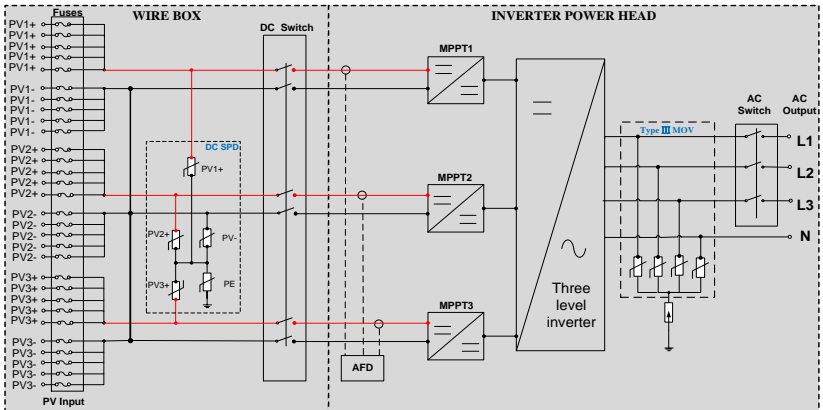

Figure 2-3 CPS SCA50/60KTL-DO/US-480 Inverter Schematic, Standard Wirebox

The Rapid Shutdown wirebox has been designed specifically for 2017 NEC Rapid Shutdown applications. This wirebox includes a powerline communications transmitter, powered by AC at the inverter output. This transmitter sends a “keep alive” signal to APS、Tigo TS4-A-F and TS4-A-2F devices at the array. When the inverter senses the loss of AC voltage by way of opening the PV system disconnect switch, inverter circuit breaker or under loss of grid events, the transmitter ceases the signal sending the MLPE devices into rapid shutdown. This rapid shutdown system has been tested and certified with the [Tigo TS4-A-F](#) and [TS4-A-2F](#) platform to conform to 690.12 of the 2017 National Electric Code. CPS SCA50/60KTL-DO/US-480 Wirebox have two models, One is the standard version of the machine, another machine is a rapid Shutdown (RSD) Wirebox equipped with APS or Tigo products. CPS SCA25KTL-DO/US-208 Wirebox only have rapid Shutdown (RSD) Wirebox equipped with APS products.

The negative fuses have been removed from this model in accordance with 690.9(C).

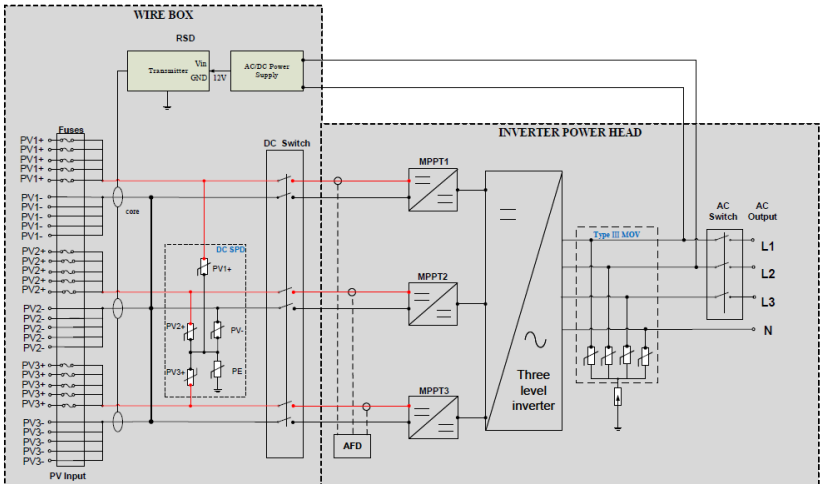

Figure 2-4 CPS SCA50/60KTL-DO/US-480 Inverter Schematic, Rapid Shutdown (RSD) Wirebox

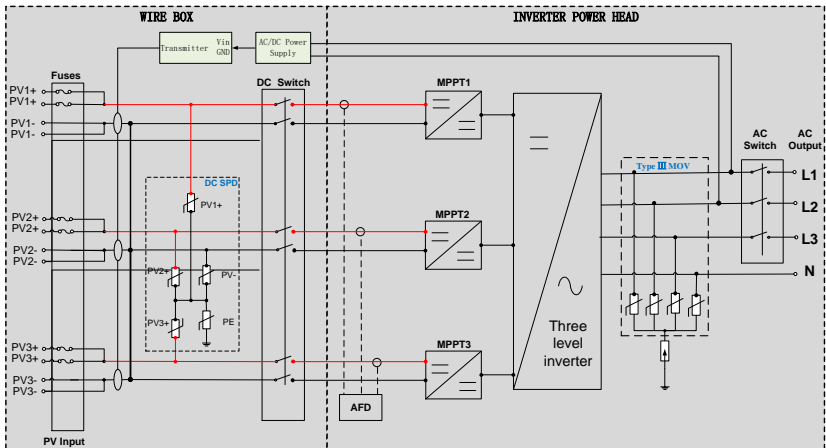

Figure 2-5 CPS SCA25KTL-DO/US-208 Inverter Schematic, Rapid Shutdown (RSD) Wirebox

2.7 Anti-Islanding Detection

The SCA25KTL-DO/US-208, SCA50KTL-DO/US-480 and SCA60KTL- DO /US-480 3-Phase String Inverters include Unintentional Islanding detection as required by UL 1741/IEEE 1547. The inverter will continuously make bi-directional perturbations to the frequency of the output current by injecting a small amount of reactive power to detect a possible islanding condition. If the grid is stable, these small perturbations will have negligible effects on the system voltage frequency. However, in an islanded condition the changes in reactive power will force the frequency of the system voltage to deviate significantly, which will trigger the inverter to cease operation and disconnect from the grid.

2.8 DC Ground Fault Protection

The inverters include residual current detection GFCI as part of the DC ground fault detection method required by UL 1741. If there is a ground fault in the PV array, the ground fault detection circuitry will detect leakage current, trigger an alarm, and the inverter will cease operation. See Chapter 5 for further information regarding GFCI Static and Dynamic trip thresholds and operation.

2.9 Surge Suppression

Table 2-1 Standard Waveform Peak Values

Standard Waveform Peak Values		
Surge Category	Ring Wave	Combination Wave
B	6kV/0.5kA	6kV/3kA

- "Standard 1.2/50 μ s - 8/20 μ s Combination Wave"
- "Standard 0.5 μ s - 100 kHz Ring Wave"

2.10 DC Arc-fault Protection

The inverters include DC Arc-fault detection compliant with UL 1699B-2018. The inverter will detect electrical noise that is indicative of a DC series arc. Upon detection of an arc-fault, the inverter will cease operation.

2.11 Module-Level Rapid Shutdown

The RSD version of the inverter wirebox includes a Sunspec powerline communication transmitter for use with APS、Tigo TS4-A-F/2F (module/rack mounted MLPE) and smart modules integrated with the APS、TS4-A-F/2F in their junction boxes. These inverters are PVRSS certified to perform module-level rapid shutdown in compliance with 2017 NEC 690.12.

When the inverter is connected to the AC grid the PLC transformer receives power via an integrated power supply. Once the transmitter is powered it will send a “keep alive” signal to the APS、TS4-A-F/2F mounted/integrated at the array. Once the inverter senses the grid is missing, whether by opening the PV system disconnect, inverter circuit breaker or by a loss of grid, the transmitter will cease sending this signal. When the APS、TS4-A-F/2F do not receive the “keep alive” signal they enter the shutdown mode with module output reduced to 0.6V. The transmitter is capable of signaling these devices up to 500’ (1000’ entire circuit length; to the module and back). **The RSD wirebox version of the SCA25KTL-DO/US-208 is required when using the APS products. SCA50KTL-DO/US-480 and SCA60KTL-D O/ US-480 are required when using the APS or Tigo TS4-A-F/2F products.**

3 Installation

This chapter describes the planning and installation procedures for the SCA25KTL-DO/US-208, SCA50KTL-DO/US-480 and SCA 60KTL-DO/US-480 3-Phase String Inverters. Please read carefully and install the products following the step-by-step instructions.

The inverter and other main items are shipped in two separate packages, consisting of A.) the main inverter enclosure and B.) the wirebox, mounting bracket, user manual, and accessory kit. Before installation, please check that the following items are included in the packages:

Table 3-1 Main Items

No.	Item	Q'ty	Note	Box
(1)	Main enclosure of the PV inverter	1		A
(2)	Wiring box of the PV inverter Standard wiring box RSD Wiring box	1	There are two types of wiring box. Standard wiring box: Integrated DC fuses with every string.	B
			RSD wiring box : With RSD function, no negative fuses.	
(3)	Mounting bracket	1	Bracket upon which the PV inverter is hung and mounted	B
(4)	Accessory kit	1	Kit contains all necessary hardware and accessories for installation	B

Table 3-2 Accessory Kit

No.	Item	Q'ty	Note
(1)	M6 X18mm Phillips screw	12	4 for securing the wiring box to the main enclosure; 6 for securing the inverter to the mounting bracket; 1 for the External Ground connection, 1 spare
(2)	5 pin PCB connector plug	1	For the RS485 communication (Input)
(3)	3 pin PCB connector plug	1	For the RS485 communication (Output)
(4)	M8 Nut	4	For the AC terminal block
(5)	M8 Flat washer	4	For the AC terminal block
(6)	M8 Spring washer	4	For the AC terminal block
(7)	Phillips screw	1	Spare (for wire-box cover)

INSTRUCTION:

The items above in Table 3-2 Accessory Kit are for the typical installation configuration. The accessories provided may vary if optional parts are purchased.

3.1 Recommendations Before Installation

See Chapter 10, Technical Data for specification ranges and limits.



NOTICE: DESIGN AND INSTALLATION RECOMMENDATIONS

Maintaining NEMA4X Rating is essential to assure safe operation of the inverter. Water ingress is likely to cause a failure that could result in an unsafe condition. The following are recommended

- ✓ Addition of weep holes or any other hole will void the warranty.
- ✓ For earlier wire box models with gland plate – the conduit connections must be strain relieved to ensure the plate to gasket interface is water tight. Water-tight metal flex conduit is one method.
- ✓ All conduit entries must be metallic to prevent propagation.
- ✓ All conduit entries must be sealed to prevent moisture ingress.
 - Sealing conduits at the other end will provide additional protection – firestop putty may be used.
- ✓ Separate conduits for + and – DC cables may prevent arc propagation outside of wire box.



NOTICE: The allowable ambient temperature ranges for the SCA25KTL-DO/US-208, SCA50KTL-DO/US-480 and SCA 60KTL-DO/US-480 3-Phase String Inverters are defined based on the following conditions:

Condition 1: -40°C to 70°C, Inverter not installed, and in storage (in packaging or unpackaged).

Condition 2: -30°C to 60°C, Inverter installed, connected to electric utility grid and operating during daylight hours.

Condition 3: No low temp limit to 70°C, Inverter installed, connected to electric utility grid but non-operating (daylight or nighttime hours).

Bulk head connector cover does not provide a water-tight seal.

PRE-INSTALLATION CHECKLIST

- ✓ Check that the inverter environmental specifications (protection degree, operating temperature range, humidity and altitude, etc) meet the requirements of the specific project location.
- ✓ Make sure that the electric utility grid voltage is within range for the grid standard chosen.
- ✓ Ensure that the local electric utility grid authority has granted permission to connect to the grid.
- ✓ Installation personnel must be qualified electricians or those who have received professional training.
- ✓ Wear and use proper PPE (personal protective equipment) during installation.
- ✓ Sufficient space according to Figure 3-3 and Figure 3-4 must be provided to allow the inverter cooling system to operate effectively.
- ✓ Install the inverter away from flammable and/or combustible substances.
- ✓ Avoid installing the inverter in locations that exceed the temperature limits specified for the inverter to prevent undesirable power loss.



NOTICE:**Outdoor Installations for Extended Periods without Power**

CPS advises against leaving inverters mounted outdoors for an extended period of time (more than 90 days) and/or allowing inverters exposed to cycles of freezing temperature without both DC and AC power connected to the inverters under normal operation.

The CPS inverter enclosures are designed to conform to NEMA4 (or IP65), however there exists the possibility of water condensation inside the inverter enclosure when it is left exposed to an outdoor environment without power to operate for an extended period of time. Moisture in the air could enter the power head of the inverter through the small opening between wiring box and power head during the time that the wiring box cover is opened for wiring purposes. When the inverter is exposed to temperature swings, especially in cold weather, moisture inside the inverter power head could condense over the aluminum heatsink area where inverter semiconductors are mounted. Water droplets on the heatsink may cause a short-circuit to live semiconductor devices. When the PV source is applied to the inverter, this PV power source could cause the inverter to fail and result in a short-circuit across the PV array.

If such a situation in which the inverter is mounted outdoors without operating power occurs, CPS recommends that the inverter power head be inspected for water condensation before any DC or AC power can be applied to inverter. Without inspection, customers will run the risk of having inverter electronic circuit damage when power is applied to inverter during startup. It is advised that customers contact CPS for further advice and to arrange schedule for CPS service personnel to perform inspection of inverter on site.

Bulk head connector cover does not provide a water-tight seal.

- CPS hotline: 855-584-7168

3.2 Mechanical Installation

3.2.1 Dimensions

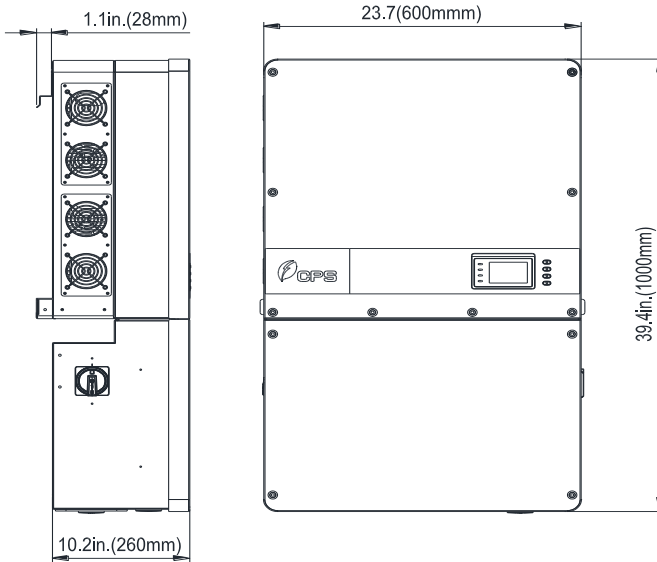

Figure 3-1 Dimensions of Inverter

3.2.2 Installation Method (see Figure 3-2)

Ensure that the mounting structure (wall, rack, roof, etc) is suitable to support the weight of the inverter. Follow the mounting guidelines below:

- (a) If the location permits, install the inverter mounted vertically.
- (b) If the inverter cannot be mounted vertically, it may be tilted backward at any angle from vertical to 15° from horizontal.
- (c) When tilted backward at $\leq 75^\circ$ from horizontal in an outdoor environment, the CPS Shade Cover (SSC-60ST) accessory is required to be installed. See Section 9.2 for more information.
- (d) Do not mount the inverter leaning forward.

(e) Do not mount the inverter upside down.

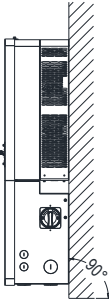

(a)

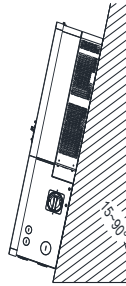

(b)

Shade cover

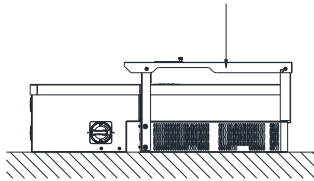

(c)

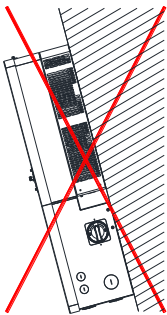

(d)

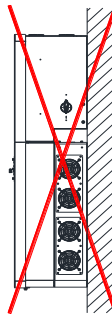

(e)

Figure 3-2 Inverter Mounting Options

3.2.3 Installation Space Requirement

The distances between the inverters or the surrounding objects should meet the following conditions:



NOTICE:

When the inverter is mounted tilted backward at $\leq 75^\circ$ from horizontal in an outdoor environment, the CPS Shade Cover (SSC-60ST) accessory must be installed on the inverter to avoid direct sunlight.



NOTICE:

The spacing between two adjacently mounted inverters must be ≥ 19.7 in (500mm). Spacing should be increased for installation locations with ambient temperature $\geq 45^\circ\text{C}$. Ensure that the air space around the inverter is well ventilated. The spacing below the inverter is intended to ensure the LCD and Keypad height are well positioned for the user, and may be decreased, however consideration must be taken for locations known to flood or have seasonal snow build up.

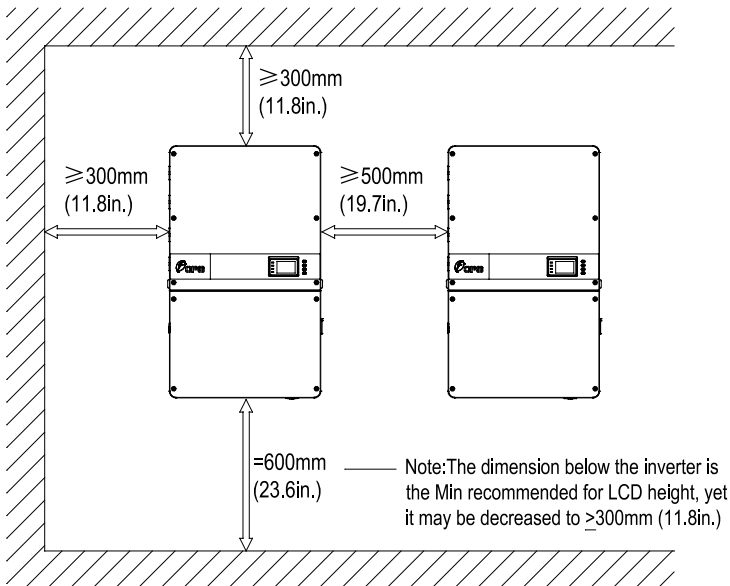

Figure 3-3 Inverter Wall Mounting Dimensions

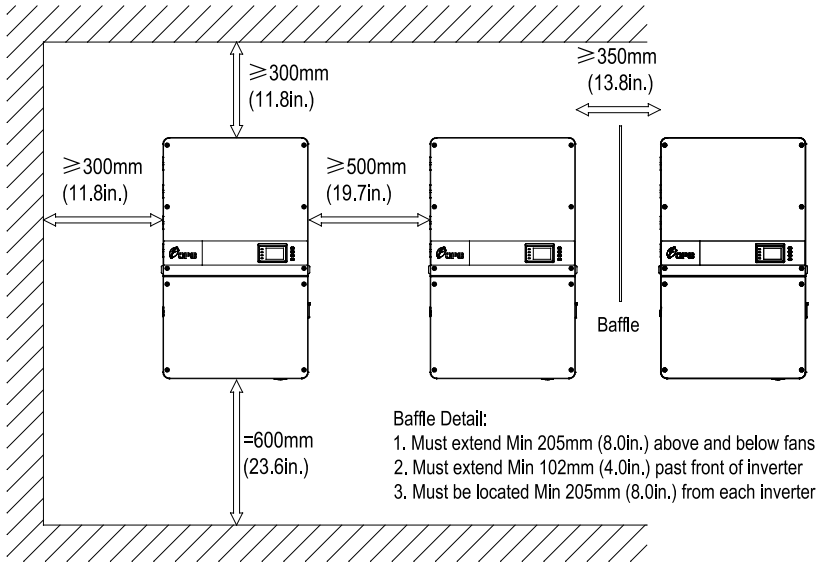

Figure 3-4 Inverter Wall Mounting Baffle Details



NOTICE:

Ensure that the air space around the inverter is well ventilated. The spacing between two adjacently wall mounted inverters may be reduced to $\geq 13.8\text{in}$ (350mm) provided a baffle is installed. Installing an aluminum or galvanized steel baffle (Not supplied by CPS) with the dimensions detailed above is intended to divert or deflect warm exhaust air from entering the adjacent inverter. Elevated ambient air temperature $\geq 45^\circ\text{C}$ will cause the inverter to enter a thermal derating mode and reduce its Active power output.

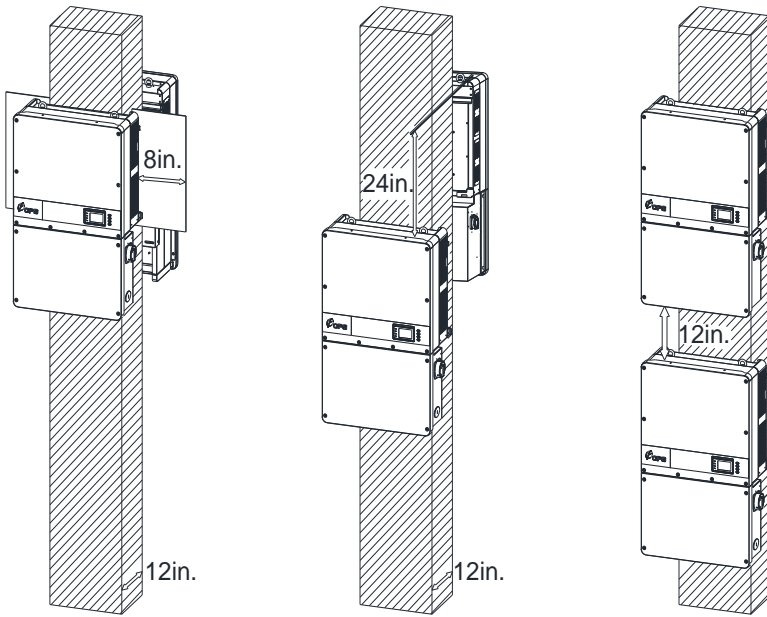
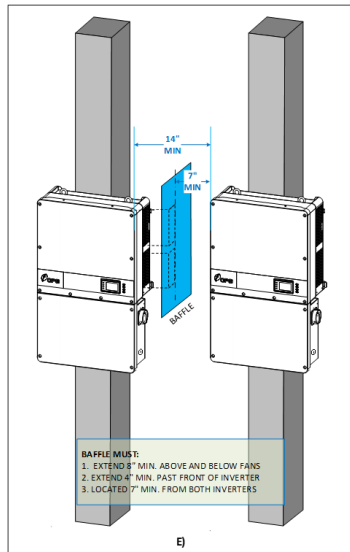
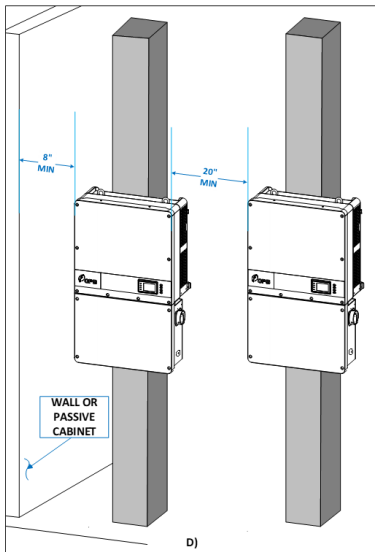
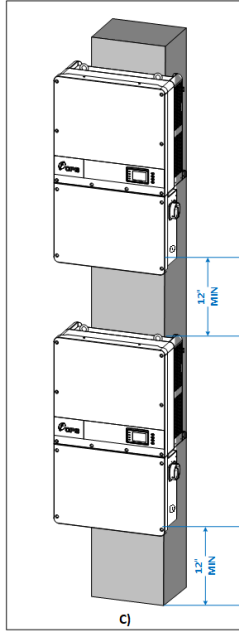
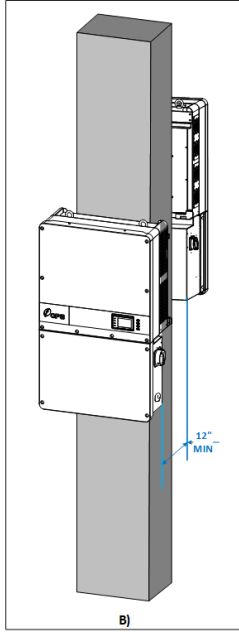
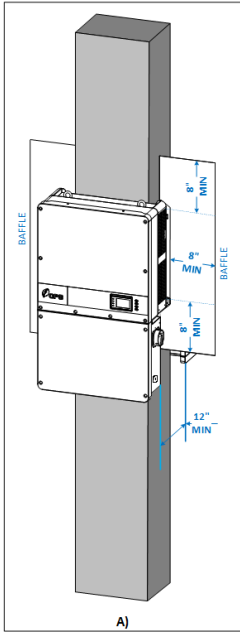

Figure 3-5 Inverter Pillar or Column Mounting Dimensions



INSTRUCTION:

If the inverter is installed on a pillar or column (instead of solid wall), the space from the bottom of one inverter to the top of the inverter below may be as small as 11.8in (300mm).



3.2.4 Mounting the Inverter onto the Bracket

Step 1 Locate and mark the 8 holes on the wall, PV racking structure, or bearing surface for attaching the inverter mounting bracket as shown in Figure 3-6.

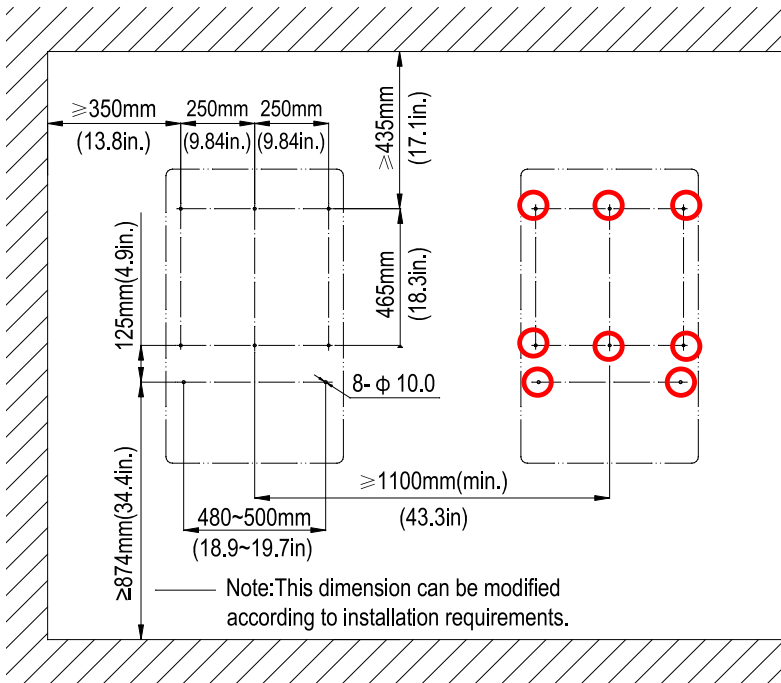

Figure 3-6 Dimensions of the Bracket Anchoring Holes for Mounting

- (a) PV Racking Mount: Locate holes or anchors at the marked positions; Fasten the **Mounting Bracket** with the **M8x25 Assembling Bolts** supplied with the Accessory Kit. Note: if mounting the Bracket to PV Racking, the M8 nuts are not provided in the Accessory Kit. Tools Required: No. 13 wrench(es)

- (b) Concrete Wall Mount: Drill holes at the marked positions with a 0.4in. (10mm) masonry bit and insert **M8 Expansion Anchors** into the holes (expansion anchors not provided); Fasten the **Mounting Bracket** with the **M8x25 Assembling Bolts** supplied with the Accessory Kit. Figure 3-7 and Figure 3-8. Tools Required: Electric drill (Φ 10mm/0.4in. masonry bit), No. 13 wrench

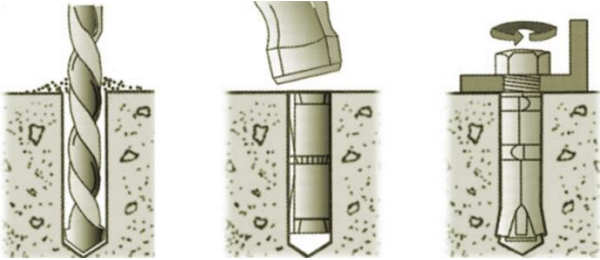

Figure 3-7 Drill holes, set Anchors, and tighten Assembly Bolts

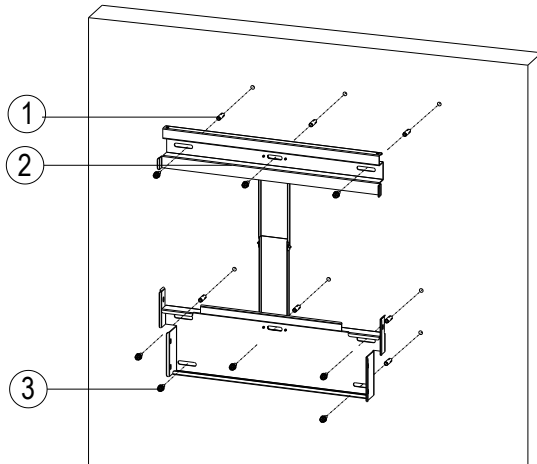

Figure 3-8 Secure the Mounting Bracket

Step 2 Hang the inverter onto the mounting bracket as shown in Figure 3-9 and Figure 3-10:

- (a) Lift mounting: Locate the lifting eyes at the top of the inverter. Use sling rope or bar (inserted through both lifting eye nuts) to lift the inverter onto the bracket. The minimum angle between the two sling ropes should be less than 90 degrees.
- (b) Manual mounting: Two people are required to safely lift the inverter by the grab handle positions marked in Figure 3-10 and mount it onto the bracket.



CAUTION:

The main enclosure of the CPS SCA25KTL-DO/US-208, CPS SCA50KTL-DO/US-480 and SCA60KTL-DO/US-480 3-Phase String Inverters is approx **56kg (123.5 pounds)**. Ensure the mounting bracket is properly installed and secured before hanging the inverter on the bracket. It is recommended to have at least 2 people to mount the inverter due to the weight of the equipment.

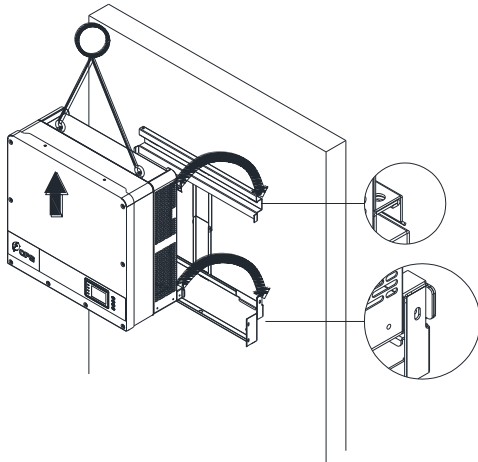

Figure 3-9 Mount the Main Enclosure on the Bracket by Lifting Sling

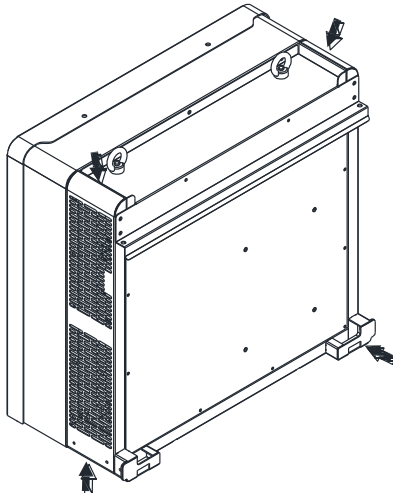

Figure 3-10 Grab Handle Position

Step 3 Install the wirebox:

- (a) Remove the cover plate at the bottom of the main enclosure.

Tool required: No. 2 Phillips head screwdriver

Remark: the covers shown below do not have waterproof function.

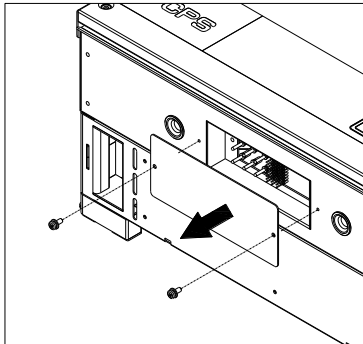

Figure 3-11 Main Enclosure Cover Plate

- (b) Remove screws securing the bulkhead cover at the top of the wirebox – **COVER IS NOT WATER TIGHT.**

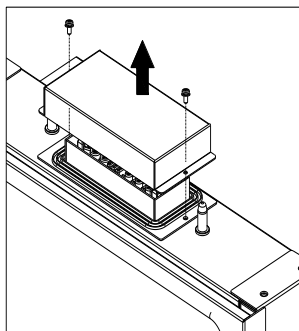

Figure 3-12 Wiring Bulkhead Cover

- (c) Save the bulkhead cover and screws, and attach the cover to the left side of the wirebox after the wirebox is attached to the

inverter enclosure. Covers may be required in the future if an inverter or wirebox is to be removed during servicing (see step 6,

(d) Figure 3-15). Tool required: No.2 Phillips head screwdriver

Step 4 Secure the wirebox to the main enclosure by using the **M6x18 screws** (4pcs) to fasten the wirebox. (see Figure 3-13). Tool required: No.3 Phillips head screwdriver or 10mm Wrench, torque value of 4 N.m (35.4in-lbs)



WARNING:

Ensure the **M6x18 screws** (4pcs) installed in Step 4 above are properly torqued and the area under the bolt-head is clear of paint. This connection provides an electrical ground bond of the wirebox to the upper/main enclosure.

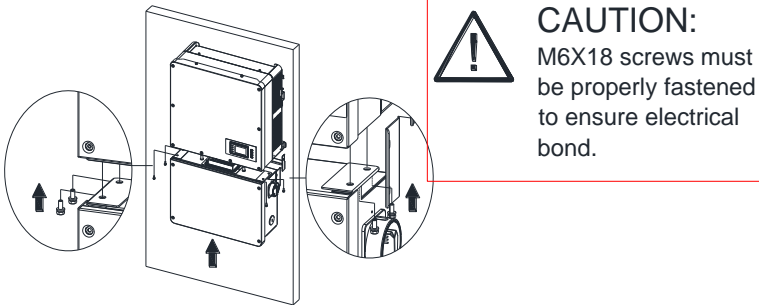

Figure 3-13 Installation of the Wiring Box

Step 5 Attach the main enclosure and the wiring box to the mounting bracket with the M6x18 screws (6 pcs). (see Figure 3-14). Tool required: No.3 Phillips head screwdriver, torque value of 4N.m (35.4in-lbs)

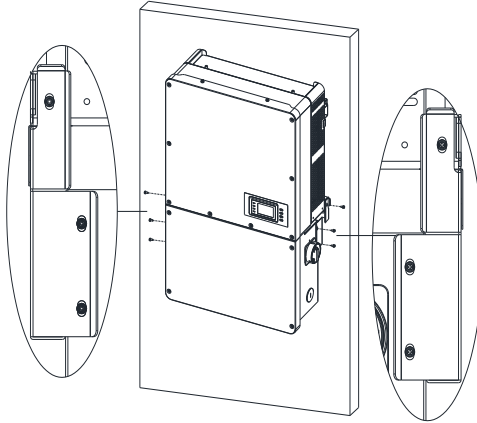

Figure 3-14 Secure the Main Enclosure and Wiring Box to the Bracket

Step 6 Attach the bulkhead cover shown in

Step 7 Figure 3-12 to the left side of the wiring box. (see

Step 8 Figure 3-15). Tool required: No. 2 Phillips head screwdriver, torque value of 1.6N.m (14.2in-lbs)

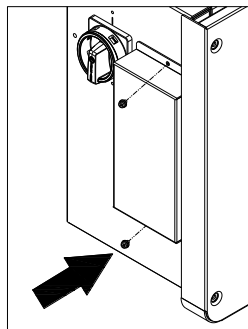

Figure 3-15 Attach the Cover to the left side of the Wiring Box

Step 9 Optional - Install an anti-theft padlock when the installation is complete. The anti-theft padlock is used to prevent the inverter from being stolen when the equipment is installed outdoors. The inverter may be locked to the bracket (

Step 10 Figure 3-16).

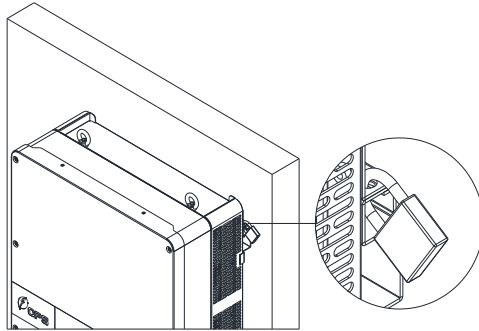
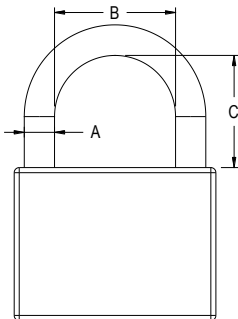

Figure 3-16 Location of the Anti-Theft Padlock

The anti-theft padlock should meet the dimensional requirements shown in Figure 3-17.



Recommended lock size:

A: Shackle diameter 3~6mm

B: Shackle width 20~50mm

C: Shackle height 20~50mm

Figure 3-17 Dimensions of Anti-Theft Padlock Shackle

3.3 Electrical Installation



NOTICE:

The SCA25KTL-DO/US-208, SCA50KTL-DO/US-480 and SCA60 KTL-DO/US-480 3-Phase Inverters must be installed in accordance with the National Electric Code, NFPA 70, and any State Codes or local jurisdictions. An MS Excel™ based Solar PV Array sizing tool is available for download at <http://www.chintpowersystems.com> and is obtainable by selecting the Product Downloads link to access the CPS String Sizing tool. This is an optional design tool to help guide designers by matching the PV panel type and quantity to the inverter's power rating.



WARNING

Prior to performing any electrical installation, ensure the **M6x18 screws** (4pcs) installed in Step 4 of section 3.2.4 Mounting the Inverter onto the Bracket are properly torqued and the area under the bolt-head is clear of paint. This connection provides an electrical ground bond of the wirebox to the upper/main enclosure.

3.3.1 Removing/Replacing the Wiring Box Cover:

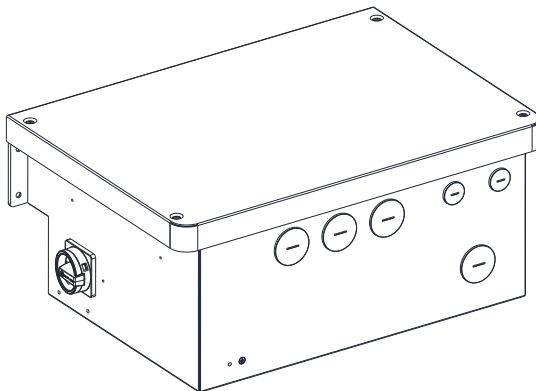

Figure 3-18 Standard and RSD Wirebox



Use a No. 3 Philips head screwdriver to remove the 4 screws on the wiring box and remove the cover. (See Figure 3-19)

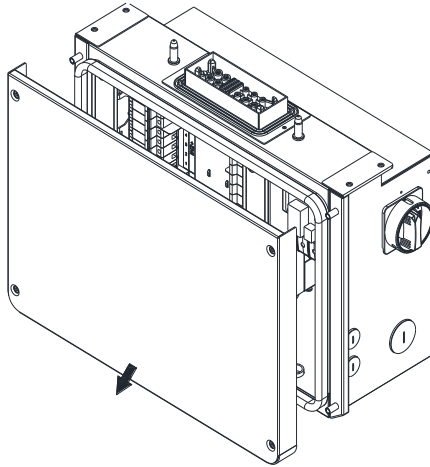

Figure 3-19 Removing the Wiring Box Cover

To reinstall the cover, replace cover and align the screws. Use a No. 3 Philips head screwdriver to secure the 4 screws on the cover. Torque to 35.4 in-lbs (4 N.m.)

3.3.2 Wiring Boxes

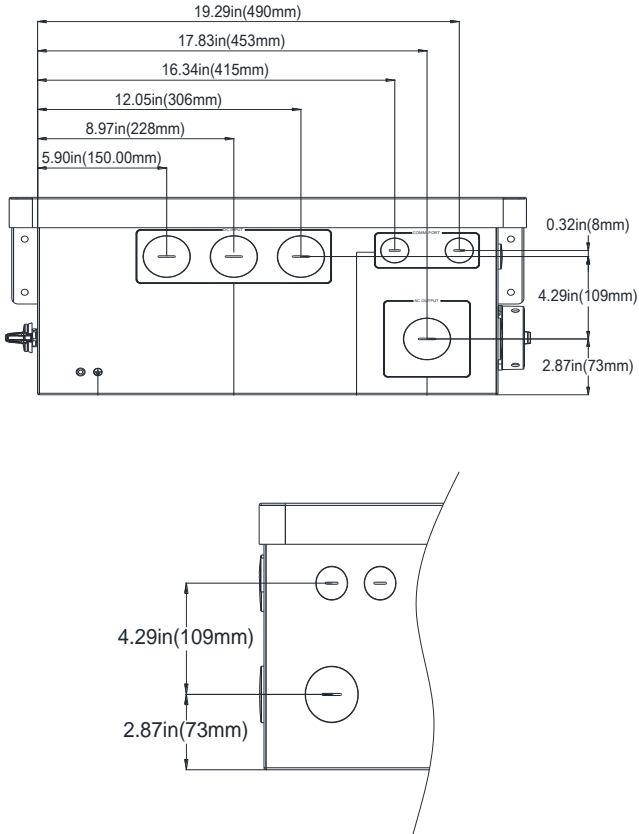
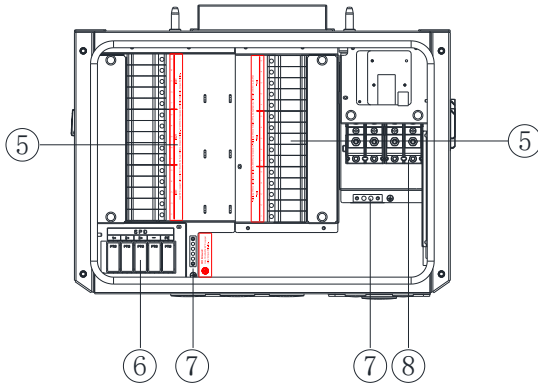

Figure 3-20 Conduit Knock-out Locations on the wirebox

- ① Knock-outs for DC input, (3) 1-1/2 inch Trade Size (1.98" Dia) and (1) removable gland plate for custom size conduit (i.e. when use of 2 inch or 2-1/2 inch Trade Size conduit is required) – later models may not have gland plates.
- ② Knock-outs for communication, 3/4 inch Trade Size (1.11" Dia)

- ③ Knock-out for AC output, (1) 1-1/2 inch Trade Size (1.98" Dia) on a removable gland plate for custom size conduit (i.e. when use of 2 inch or 2-1/2 inch Trade Size is required)
- ④ External ground connection point (M6)



**Figure 3-21 Internal Connection Points within the Standard wirebox
(only for CPS SCA50/60KTL-DO/US-480)**

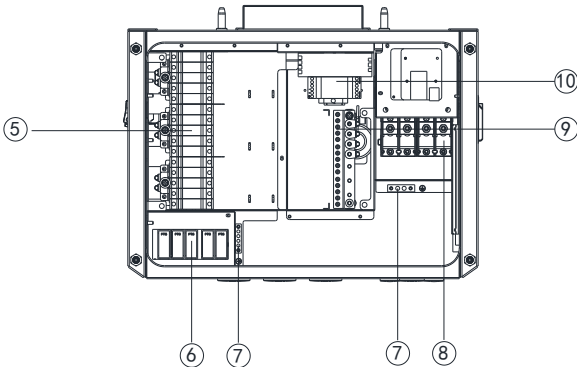

**Figure 3-22 Internal Connection Points within the RSD wirebox
(only for CPS SCA50/60KTL-DO/US-480)**

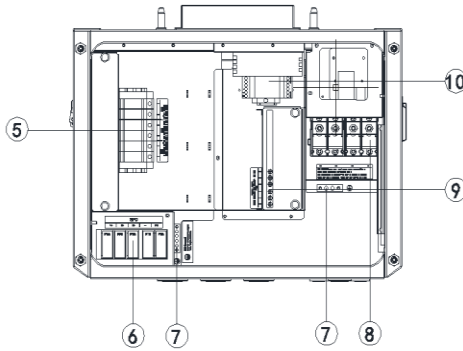

**Figure 3-23 Internal Connection Points within the RSD wirebox
(only for CPS SCA25KTL-DO/US-208)**

- ⑤ DC Input fuse holder/terminal
- ⑥ DC SPD (Surge Protective Device)
- ⑦ Internal ground terminal(s)
- ⑧ AC output terminal block
- ⑨ Negative DC input busbar
- ⑩ Rapid Shutdown transmitter

3.3.3 DC Connection

3.3.3.1 Working mode

These inverters are factory configured with three MPPTs which are electrically divided into separate PV input zones: PV Input-1, PV Input-2, and PV Input-3. Each 5-string PV input zone operates as a separate and independent Maximum Power Point Tracker (MPPT). Independent mode can be very useful for sites with partial shading of the array or with arrays consisting of different tilt or azimuth. Each MPPT employs a method known as P&O (perturb and observe) for seeking and tracking the maximum power point along the I/V curve of the PV array. During operation each MPPT will make small adjustments to the PV voltage and then execute a

power measurement; if the PV power increases, further voltage adjustments in that same direction are performed until the PV power no longer increases.



INSTRUCTION:

PV input power from the array may be unbalanced between the three MPPT zones, however every effort should be made to design within one string count difference. See Table 3-3.

When designing the PV system ensure each PV string within a single PV input zone includes the same module type (Mfg and ratings), same series module count, and same module orientation (tilt and azimuth) to maximize MPPT performance and energy harvest.

Table 3-3 DC Input Specifications (Independent Mode)

Specification	(Independent Mode - per MPPT)		
	SCA25KTL-DO/US-208	SCA50KTL-DO/US-480	SCA60KTL-DO/US-480
Max PV Power	14.5kW (Combined ≤ 37.5Kw)	30kW (Combined ≤ 75Kw)	33kW (Combined ≤ 90kW)
Max PV Voltage	1000Vdc	1000Vdc	1000Vdc
Start-up Voltage / Power	330 / 80W	330 / 80W	330 / 80W
Operating Voltage	200-950Vdc	200-950Vdc	200-950Vdc
MPPT Voltage Range	480-850Vdc	480-850Vdc	540-850Vdc
Maximum PV Current (Isc x 1.25)	45A	68A	68A

Table 3-4 DC Input Specifications (Parallel Mode)

Specification	(Parallel Mode - 3 MPPTs combined)		
	Model	SCA25KTL-DO/US-208	SCA50KTL-DO/US-480
Max PV Power	37.5kW	75kW	90kW
Max PV Voltage	1000Vdc	1000Vdc	1000Vdc
Start-up Voltage / Power	330 / 80W	330 / 80W	330 / 80W
Operating Voltage	200-950Vdc	200-950Vdc	200-950Vdc
MPPT Voltage Range	480-850Vdc	480-850Vdc	540-850Vdc
Maximum PV Current (Isc x 1.25)	135A	204A	204A



INSTRUCTION:

The default Working Mode of the inverter is Independent Mode (3 MPPTs). The Working Mode may be configured to operate in Parallel Mode (1 MPPT) only as an exception.

Every effort should be made to design within one string count difference for each of the three MPPTs to avoid unnecessary power clipping. When the input power for one MPPT zone exceeds the individual maximum allowed (Max PV Power), however the combined input power is below the inverter maximum input specifications, the inverter may be set to operate in **Parallel Mode** (1 MPPT). In this mode, all strings should be the same module type (Mfg and ratings), same series module count, and same module orientation (tilt and azimuth).

Parallel Mode is not preferred since it affects the sensitivity of the AFCI and may increase the possibility of false DC Arc-Fault trips. Setting to Parallel Mode must be approved in advance by CPS and must be performed by a CPS Service Technician.

Contact CPS Customer Service for further information.

Select the DC conductor size and material for the inverters according to the following configuration table:

Table 3-5 DC Terminal Specifications

Terminal	Acceptable wire range
DC input (+ / -)	#12-8AWG (75/90°C Copper only) when terminating to the fuse holders #6~2AWG (Copper or Aluminum) when using the Bypass Terminal kit accessory.



INSTRUCTION:

The SCA25KTL-DO/US-208 、 SCA50KTL-DO/US-480 and SCA60KTL-DO/US-480 3-Phase Inverters are designed operate with ungrounded arrays, although the PV system requires a DC EGC (equipment grounding conductor) to ensure operational safety. The grounding busbars are electrically bonded by way of the inverter chassis.

3.3.3.2 DC Fuse Configuration/Selection

The CPS SCA25KTL-DO/US-208 、 CPS SCA50KTL-DO/US-480 and SCA60KTL-DO/US-480 inverter wire boxes include touch safe fuse holders and preinstalled 20A DC fuses as factory standard. Ensure that the appropriate fuse values are used depending on the configuration of the PV array and by performing PV fuse sizing calculations for each string.

1. Each DC input conductor for the PV string requires fuse protection.
(2014 NEC and earlier editions)
2. The voltage rating of the fuse must be at least 1000V_{DC}.

3. The ampere rating of the fuse is generally selected as $1.56 \times$ module Isc of the PV string. Refer to NEC 690.8 for Circuit Sizing and Current requirements.

Table 3-6 DC Fuse selection

25-50 -60 kW	Brand	15A	20A	25A	30A
	Mersen	HP10M15	HP10M20	HP10M25	HP10M30
		15A/1000V	20A/1000V	25A/1000V	30A/1000V

The 1000V_{DC} Mersen HP10M PV fuse series are required as replacement fuses when necessary. Detailed fuse information is available at <http://www.ep-us.mersen.com/>.

The touch safe fuse holders and wirebox internal factory wiring are designed to accept either 15A, 20A, 25A, or 30A rated fuses. The larger rated fuses may be required for combined input strings; for example, when Y branch connectors are used with DC field wiring to reduce PV source circuit home runs. CPS allows replacement of the factory installed 15A fuses with appropriate ampere ratings, however CPS does not provide nor stock these fuses.



NOTICE:

When installing replacement 25A or 30A fuses, these fuses may not be installed in adjacent fuse holders. An empty or unused fuse holder must be positioned between each 25A/30A fuse within each MPPT.

When Y branch connectors or harnesses are used with DC field wiring to reduce PV source circuit home runs, the Y-Comb Terminal Block may be used as an optional accessory. Refer to section 9.3 for further detailed information.

Use of fuses from other manufacturers or incorrectly sized fuses

can cause either equipment damage or create an unsafe working condition. Any damage resulting from use of incompatible fuses is not covered by the CPS warranty.



NOTICE:

Note 1: The temperature rating of the PV Source circuit conductors should be no less than 90°C (194°F).

Note 2: The recommended fuse values are configured based on the condition that the input strings are the same (module type and length).

Note 3: The temperature rating of the fuse holder terminals is (90°C).

3.3.3.3 DC Conductor Connection

To ensure the optimum performance of the inverter, please read the following guidelines before performing any DC connections.

1. Confirm the maximum open circuit voltage of the PV modules is lower than 1000VDC under any conditions.
2. Confirm that the PV modules for each MPPT within the inverter are of the same type and specification before connection.
3. Ensure correct polarity of the PV Strings before terminating the DC source circuits within the wirebox. Referring to Figure 3-24, the wiring from the PV string pairs must be checked according to the following steps:
 - (a) Use a multi-meter to measure the PV strings' conductor ends and check the polarity.
 - (b) The positive (+) terminal of the conductor should match the positive (+) terminal of inverter's DC input.

- (c) The negative (-) terminal of the conductor should match the negative (-) terminal of inverter's DC input.



NOTICE:

It is important to use a multi-meter to check the polarity of the DC source circuit conductors to avoid any risk of reverse polarity.



WARNING:

A reversed string is not protected by the inverter and can cause severe damage to equipment and personnel.

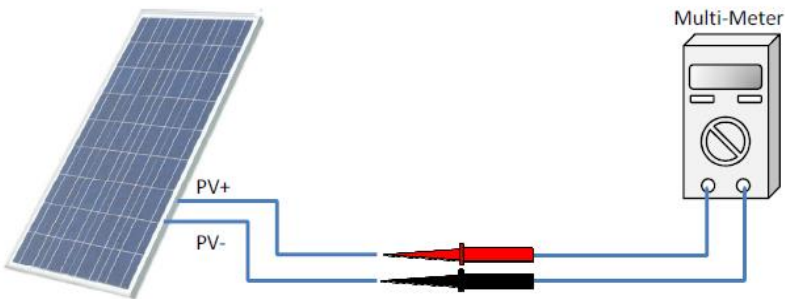



Figure 3-24 Polarity Check

3.3.3.4 DC Fuseholder Torque Specification

The inverter wiringbox may be assembled using fuse holders supplied by either Sinofuse or Mersen (Ferraz Shamut). The touch safe fuse holders have unique terminal torque values specified by their manufacturers. See Table 3-7 for specified torque values.

Table 3-7 DC Fuse Holder Torque Value by Manufacturer

Sinofuse		Mersen (Ferraz Shamut) USM1	
	<p>Single Conductor Specified Torque: 6-14AWG:26.55in-lbs(3.0N.m)</p>		<p>Single Conductor Specified Torque: 6-14AWG: 26.55in-lbs (3.0 N.m)</p>



WARNING:

Failure to apply proper torque to the fuse holder terminals may result in an improper conductor termination and cause excessive heat or fire.

3.3.3.5 DC Connection for Standard and RSD Wirebox

- Using the 1-1/2 inch openings.** Remove the factory installed liquid-tight hole plugs from the DC knockout holes in the wiring box and install 1-1/2 inch Trade Size conduit and conduit fittings. If the use of smaller conduit is desired, proper weather-tight reducing bushings may be installed. Confirm all fittings are NEMA 4X rated, properly tightened, and route the DC source circuit conductors through the conduit into the wiring box.
- Refer to the connection method of standard wiring box. The RSD transmitter sends the powerline communications (PLC) signal through the negative conductors via the busbar. AC power to the inverter is required in order to turn on the transmitter and signal the array.

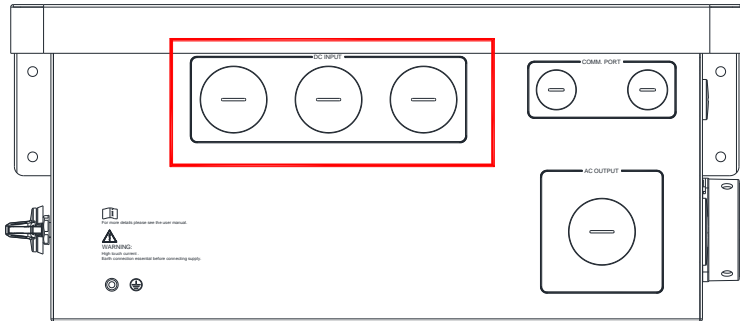

Figure 3-25 DC Input connection

Table 3-8 Tools Required for Cable Termination

No.	Tools	Remark
1	#2 Phillips head screwdriver	Torque value: 3 N.m (26.55in-lbs)

3. **Terminate at fuseholders.** The RSD wirebox only contains fuseholders for the positive DC conductors. Follow instructions in step 4 for the negative conductors. Strip approximately ½ inch of the cable jacket from the end of the string conductor. Insert the conductor into the fuseholder terminal ensuring the stranding of the conductor remains firmly twisted and does not separate. Tighten the screw clamp to the torque specified in Table 3-7. Continue terminating the remaining strings in this manner for each MPPT (PVIn1, PVIn2, PVIn3).
4. **Terminate at busbar (RSD wirebox).** The RSD wirebox only contains fuseholders for the positive DC conductors. Follow instructions in step 3 for the positive conductors. The negative DC conductors are to be terminated on the busbar. Strip approximately ½ inch of the cable jacket from the end of the string conductor. Insert the conductor into the busbar ensuring the stranding of the conductor remains firmly twisted and does

not separate. Tighten the screw to the torque specified in Table 3-7. Continue terminating the remaining negative DC conductors in this manner for each MPPT (PVIn1, PVIn2, PVIn3).

5. Bypass Terminal option for standard wirebox. **Fuse Bypass Terminals are available as an optional accessory when external PV string fused combiners are used. The Bypass Terminals allow for larger single conductors to be terminated at each MPPT within the wirebox, bypassing the input fuses as shown in Figure 3-26. See Section 9 Accessories for installation information.**

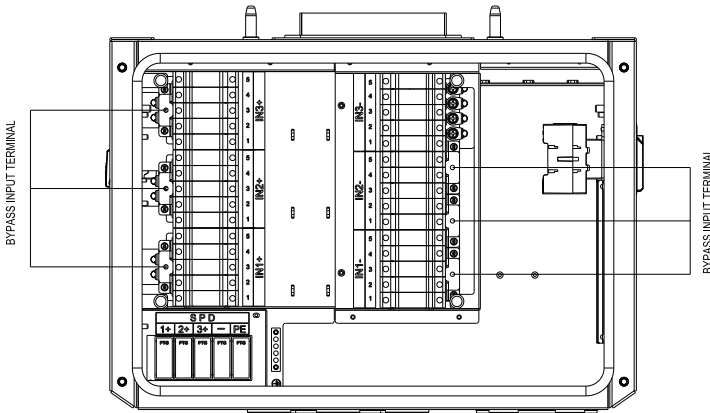

Figure 3-26 Bypass Terminal option installed within the Standard wirebox

(Only for CPS SCA50/60KTL-DO/US-480)

Before terminating the PV conductors, verify connector specifications (Table 3-9) and always verify polarity to avoid risk of reverse polarity.

Table 3-9 Connector Specifications

Contact size	4mm ² /AWG12
Rated Current (At 85°C Ambient)	45A
Reted voltage	UL600V DC TUV 1000V DC
Contact resistance	0.25mΩ
Degree of protection,mated	IP68
Strip length	7.0mm (9/32")

3.3.4 AC and Ground Connection

The following section describes the AC and ground connections.

3.3.4.1 Acceptable Transformer Configurations

The SCA25KTL-DO/US-208 inverters operate at 208V_{AC}/Wye output, SCA50/60KTL-DO/US-480 inverters operate at 480V_{AC}/Wye output. If another voltage/configuration is required a transformer may be necessary.

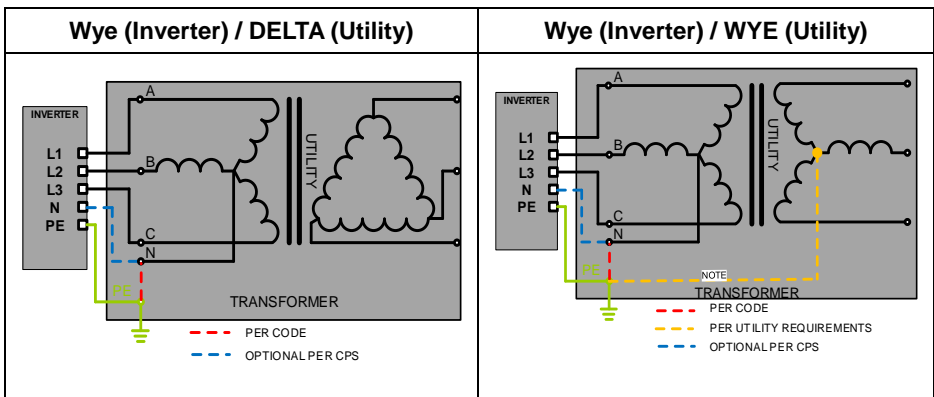

NOTE: If the transformer neutral is not connected to ground, additional ground fault detection must be added external to the inverter per NEC 250.21

NOTE: If the transformer neutral is not connected to ground, additional ground fault detection must be added external to the inverter per NEC 250.21

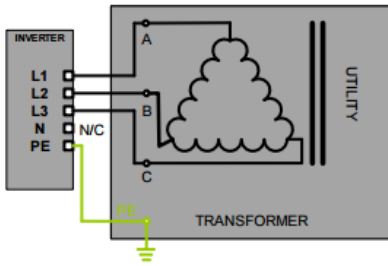

EXTERNAL AC GROUND FAULT DETECTION REQUIRED

In a Delta connected system, the inverter does not detect AC Side Ground Faults. Only DC Side Ground Fault protection is provided by the inverter. Additional AC ground fault detection must be added external to the inverter per NEC 250.21.

Figure 3-27 AC Acceptable Transformer Winding Configurations

NOTES:

1. The nearest upstream transformer should be a grounded WYE on the inverter side. The Neutral on the Utility Side (H0) and Inverter Side (X0) may be connected internally and brought out as one terminal in the LV compartment and labeled (H0X0).
2. Transformer short-circuit impedance (Z%) should be less than 6%.
3. The transformer VA rating should be at least 100% of the sum of the connected inverter VA ratings.
4. CPS recommends the **transformer VA rating be selected** based on IEEE C57.159-2016 **Guide on Transformers for application in Distributed Photovoltaic (DPV) Power Generation Systems**. It is the responsibility of the system designer to determine and take in account the reliability of the transformer or other system parameters.
5. The transformer does not require a static shield.
6. The maximum number of inverters connected to a single transformer is 70.
7. The recommended maximum voltage-drop on the Inverter to Point of Common Coupling (to the grid) is 2% at full load – including conductor temperature considerations. Voltage drop greater than 2% may require changing the transformer tap or as a last resort adjusting the GridMaxVolt trip point settings.

3.3.5 AC Connections

This section includes instructions to connect the AC conductors to the inverter and grounding options.

Table 3-10 Tools Required for Cable Termination

No.	Tools	Remark
1	No. 2 Phillips head screwdriver	3 N.m (26.55in-lbs)

1. **Using the 1-1/2 inch openings.** Remove the liquid-tight hole plug from the right side or bottom of the AC input portion of the wiring box to install 1-1/2 inch Trade Size conduit and conduit fittings into the hole. Then route the cables through the conduit inside the wiring box.

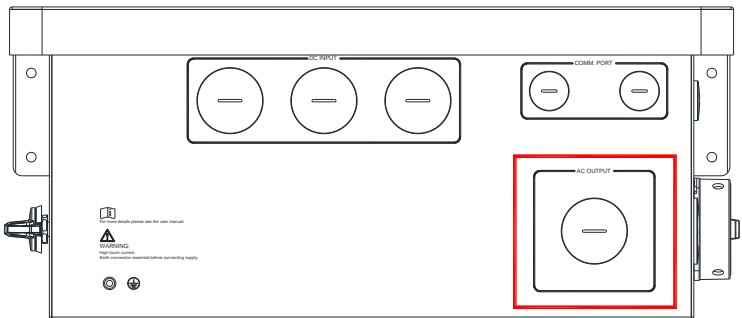

Figure 3-28 AC Input connection



NOTICE:

Terminate the Ground cable prior to terminating the AC cables.

2. Grounding/Bonding. The inverter provides 1 grounding connection on the AC side and one bonding location. These configurations are illustrated below (Figure 3-29).

- (a) Grounding via the ground busbar (left) [1] This is required for grounding the equipment by running the EGC with the ungrounded conductors.
- (b) Bonding via the external grounding point (right) [2]. The external bonding connection is provided in case the inverter/mount needs to be bonded to a metallic structure on which it may be mounted.

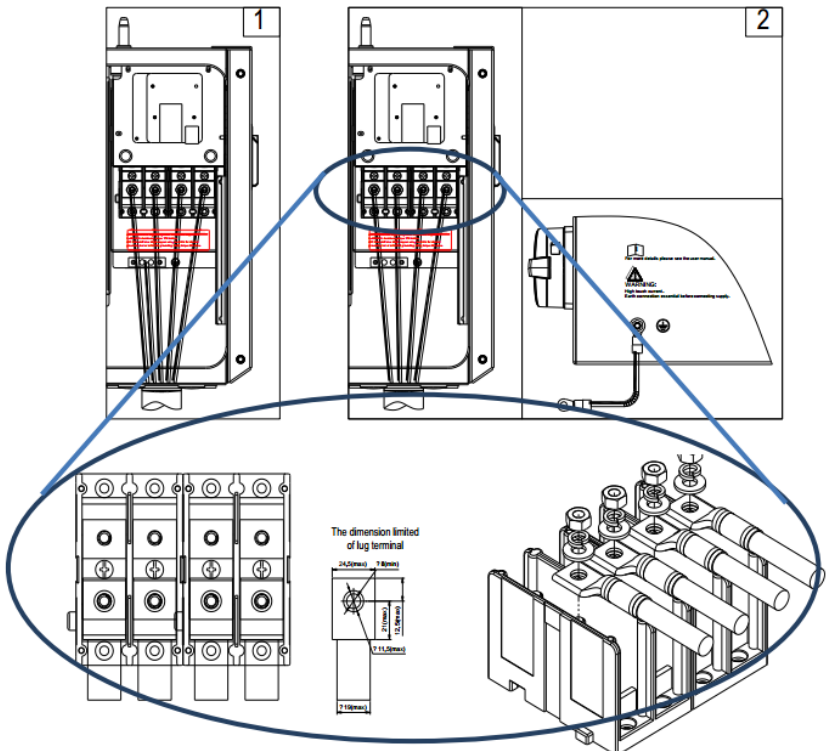

Figure 3-29 AC Output and Ground Cable Connection

Table 3-11 Torque and Conductor Specifications

Connection Point	Conductor Range	Torque Value
AC output terminal block	L1/L2/L3: 3 - 3/0AWG (75/90 °C CU) 2 - 3/0AWG (90 °C AL) 1 - 3/0AWG (75 °C AL) N: 8 - 3/0AWG (75/90 CU/AL)	14.25 N-m (126 in-lbs)
Internal grounding bar	6-4 AWG (CU)	5.65 N-m (50 in-lbs)
External grounding point	6-4 AWG (CU)	5.65 N-m (50 in-lbs)

The maximum acceptable conductor size that may be terminated to the AC output terminal is restricted based on the compression lug maximum dimensions shown in Figure 3-

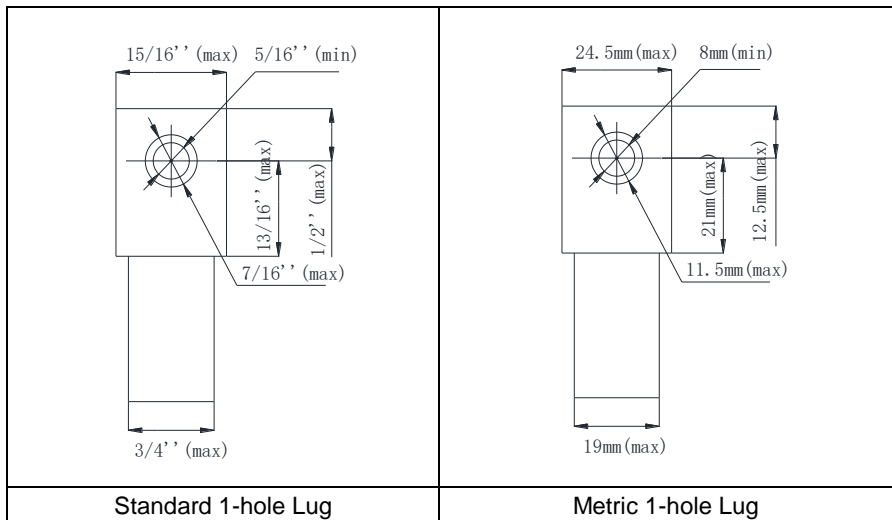

Figure 3-30 Compression Lug (OT Terminal) maximum dimensions



INSTRUCTION:

The neutral conductor from the inverter to point of interconnection (POI) is optional. The function of the neutral, when used, is to provide a point of reference for measurement purposes that is essentially at ground potential. The neutral conductor is for control or measurement purposes only, and therefore may be sized according to NEC section 705.95(B). The ground conductor (PE) is sized to section 250.122.

Use the OT type terminal to connect the AC conductors to the AC terminal block and connect the PE (GND) cable to the grounding terminal block. The neutral conductor is optional. The inverter may be wired as a 3-wire or 4-wire connection, the PE ground is ALWAYS required. When terminating the ground at the busbar a ferrule is recommended but not required. (See the 1st diagram in Figure 3-) Set up the conductors referring to Figure 3-30.

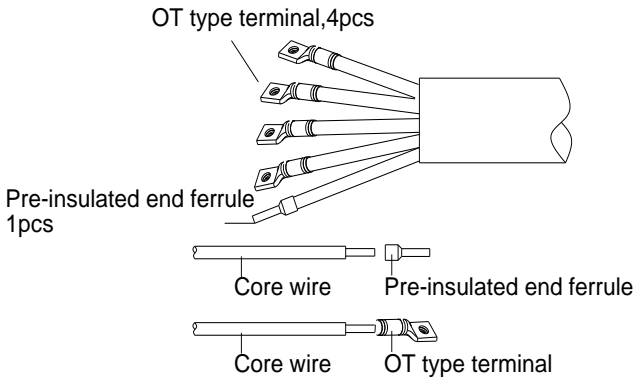

Figure 3-30 AC output and internal ground conductor set up

When bonding the inverter/mount to a metallic structure is required, use the OT type terminal to connect the ground conductor to the external bonding point at the bottom of the wiring box. The bonding point is located at the bottom of the wirebox as shown in Figure 3-31.

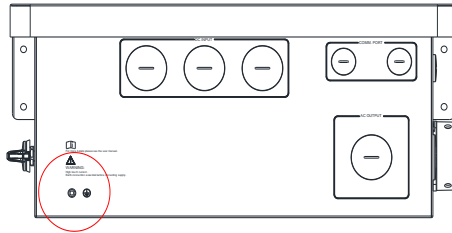

Figure 3-31 External Ground Point Location of wirebox



NOTICE:

Always connect the Ground conductor (EGC) before terminating any of the AC conductors.

When the output of the inverter is connected to the grid, an external AC circuit breaker is required to be installed to safely disconnect the inverter from the grid should an over current event occur.

The Grid connection type should be a 4-wire Wye, grounded neutral, the inverter may connect to the grid via 3 or 4-wires. The neutral conductor from the inverter to point of interconnection (POI) is optional. A floating delta is allowed, but ground fault protection must be provided external to inverter.

Either 3-pole or 4-pole AC circuit breaker (OCPD) may be selected as per the following table. Selecting a breaker of another size may either result in nuisance tripping or rejection from the AHJ.

Table 3-12 Specification of AC Breaker Selection

Inverter	Min AC OCPD	Max AC OCPD
CPS SCA25KTL-DO/US-208	100A	125A
CPS SCA50KTL-DO/US-480	90A	110A
CPS SCA60KTL-DO/US-480	100A	125A

3.4 Communication Connection

CPS SCA25KTL-DO/US-208, CPS SCA50KTL-DO/US-480 and SCA60KTL-DO/US-480 inverters support industry standard Modbus RS485 communication.

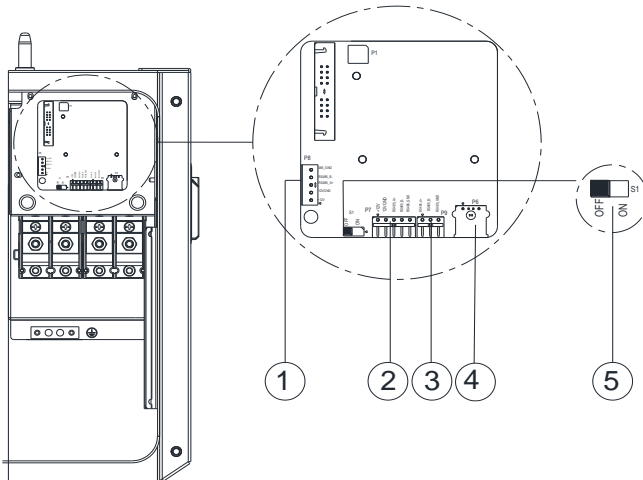
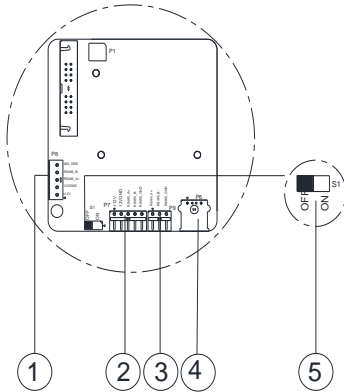

Figure 3-32 Communication Board in the Wirebox

3.4.1 Description of the Communication Board



① RS485 P8 (Debug only)

1. 12V+
2. 12VGN D
3. RS485_A+
4. RS485_B-
5. 485_GND

② RS485 P7 (Communication Input)

1. 12V+
2. 12VGN D
3. RS485_A+
4. RS485_B-
5. RS485_GND

③ RS485 P9 (Communication Output)

1. RS485_A+
2. RS485_B-
3. RS485_GND

④ USB Port P6: Firmware upgrade

⑤ Selector Switch (S1): 120Ω terminal resistor switch for communications.

1. **ON**: Enable termination resistance
2. **OFF**: Disable termination resistance

Figure 3-33 Communication Connection Interfaces

3.4.2 RS485 Communication

CPS recommends the following cable for inverter RS485 communications:

UTP CAT-5e or (3) 18-22AWG communication cables.

It is recommended that industrial grade shielded RS485 cable be used in lieu of unshielded twisted pair. Communication cable such as (CAT5) or Belden 3106A cable for RS485 5 pin connector is preferred.

RS485 communication cables are connected via the 5-pin connector to the port labeled (2) in Figure 3-33. When creating a network of multiple

inverters, the cables are terminated to the same 5-pin connector and 3-pin connector. Figure 3-34 shows a single inverter communication connection in (1) and a network configuration in (2).

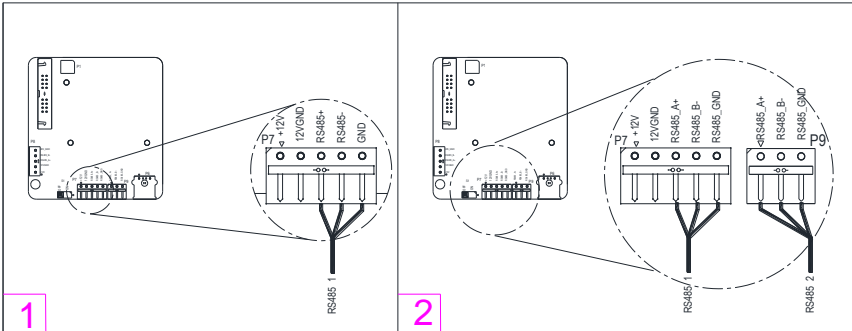

Figure 3-34 RS485 Connection of Communications Board

3.4.3 RS485 Network Set-up

When the inverters are monitored via the RS485 communication, a unique RS485 address for each inverter can be set up through the LCD interface. Up to 32 inverters can be connected in the RS485 communication network. The daisy-chain topology is recommended for the RS485 network connection to minimize noise and bus reflections, as shown in Figure 3-35. Other communication topologies, such as the star networks, are not recommended. All RS485 connections must be terminated in a serial fashion and not to exceed 32 in total.

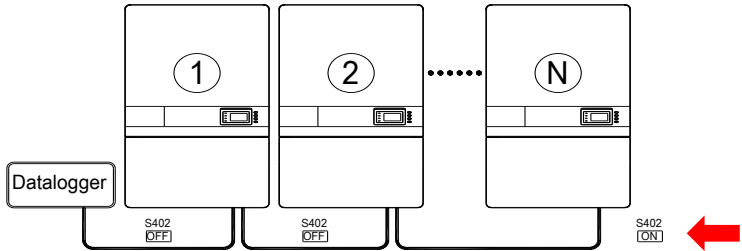

Figure 3-35 RS485 Network Connection



DANGER:

Disconnect the inverter from the AC grid and PV modules before removing covers or opening the equipment. Wait at least 5 minutes after disconnecting from the DC and AC sources before servicing or maintaining the inverter. Ensure hazardous high voltage and energy inside the inverter has been discharged prior to servicing.

If there are multiple inverters in the RS485 network, the selector switch S1 of the last inverter in the daisy-chain should be in ON position, to have the 120Ω terminal resistor enabled. The selector switch S1 of all other inverters should be in the OFF position to disable the terminal resistor.

3.4.4 Communication Wiring

Instructions for wiring the communications of one or a network of inverters:

1. Open the inverter wiring box. Refer to Section 3.3.1 for instructions and torque requirements when replacing cover.
2. Bring the communication cables into the wiring box through the provided knockout holes at the bottom, using similar methods to the AC and DC wiring. Conduit and knockouts must be sealed and water tight to maintain the NEMA 4X rating.
3. Connect the RS485 wires to the P7 connector (network P7 and P9) ensuring correct polarity and using a shielded twisted pair cable.
4. If the inverter is the last Modbus device in the daisy chain, make sure the Modbus termination switch S1 is in the ON position enabling Modbus termination. Do not turn the switch to the ON position in any other inverters of the daisy chain. If there is only one inverter, the Modbus termination switch S1 should be set to ON.
5. The shield of the individual cables must be open (not connected to ground) on one end – the other end of the shield must be grounded. Failure to follow this installation practice will increase lightning surge damage to the inverter and will void the warranty. See application not on website:www.chintpowersystems.com/resources.shtml#application

4 User Interface

This section is intended to orient the user with the inverter interface prior to turning the system on and commissioning.

4.1 Description of LCD Panel

The inverter's LCD panel consists of the LCD screen, four LED status indicator lights, a buzzer, and four user keys, as shown in Figure 4-1.

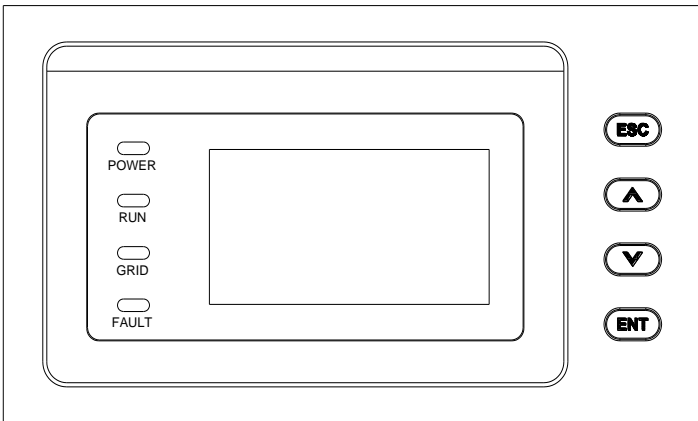

Figure 4-1 LCD Panel

The LCD panel includes a screen-saver function to increase the service life of the display. If there is no user activity or operation (key press) for greater than 1 minute, the display will enter the screen-saving mode to protect the screen and prolong the service life.





During normal inverter operation, a key press or any warnings or system faults that may occur will cause the LCD to exit screen-saver mode.

Interpretation for the indicator lights is shown in Table 4-1 and function of the keys is shown in Table 4-2.

Table 4-1 LED Indication

LED light	Name	Status	Indication
POWER	Working power light	Light on	Energized (control panel starts to work)
		Light off	Power supply not working
RUN	Grid-tied operation indication light	Light on	In grid-tied power generation state
		Flash	Derated running status (light up 0.5s, light off 1.6s)
		Light off	In other operation status or power supply not working
GRID	Grid status indication light	Light on	Grid is normal
		Flash	Grid fault (light up 0.5s, light off 1.6s)
		Light off	Power supply not working
FAULT	Fault status indication light	Light on	Indicates a Fault
		Slow flash	Indicates Alarm (light up 0.5s, light off 2s)
		Fast flash	Protective action (light up 0.5s, light off 0.5s)
		Light off	No fault or power supply not working

Table 4-2 Definition of the Keys

Key	Description	Definition of function
	Escape key	Back/end/mute
	Enter key	Confirm entering the menu/confirm set value/Switch to parameter setting mode
	Up	Page up in selection menu/+1 when setting parameters Press more than 1 second to go to the last number when setting the parameters. eg: from 2008 to 2020
	Down	Page down in selection menu/-1 when setting parameters Press more than 1 second to go to the next number when setting the parameters. eg: from 2008 to 2020

4.2 Operation State

“**POWER**” LED indicates that the system is energized and under DSP control when “POWER” lights up.

“**RUN**” LED will illuminate when the inverter detects that the grid connection conditions meet the requirements and power is being fed into the grid. The “RUN” LED will blink if the grid is in a de-rated running state while feeding power into the grid. Derate may be caused by low grid voltage; mppt voltage out of range; or excessive temperature.

“**GRID**” LED will illuminate when the grid is normal during inverter operation. Otherwise, the “GRID” LED will continue to blink until the grid restores to normal.

“**FAULT**” LED will blink quickly as a fault (except grid fault) occurs. The “FAULT” LED will stay illuminated until the fault is eliminated. The LED will blink slowly when an alarm occurs. The “FAULT” LED remains illuminated when an internal fault occurs.

4.3 Interface Types

Users can perform the corresponding operations with the 4 function keys, described in Table 4-2, according to the indications of the LCD display.

The LCD screen will display different interfaces based on the operation modes of the inverter. There are four operation modes: **Logo** interface mode (as shown in Figure 4-2 LOGO Interface), **Normal operation** and **Standby** modes (as shown in Figure 4-3 Default Display Interface for Normal Operation), and **Fault** mode (as shown in Figure 4-4 History Record Interface).

1. The LCD interface starts with the company logo once the system is energized, as shown in Figure 4-2.



Figure 4-2 LOGO Interface

2. While the inverter is in **Normal Operation** mode (and not in screen saver) the interface indicates PV voltage, PV current, Grid voltage, instant power, daily generated power and time. This is the "Default Indication Interface."

3. The inverter will enter **Standby** mode when the output voltage and power of PV modules do not meet the startup conditions or PV voltage and input power are lower than the set value. The inverter will check automatically whether it meets the startup conditions in this mode until it turns back to normal mode. The inverter will switch from standby mode to fault mode if a malfunction occurs.

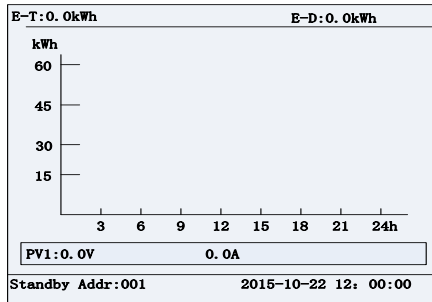

Figure 4-3 Default Display Interface for Normal Operation

4. If the inverter experiences a Fault it will enter Fault mode and display the current or most recent faults.



Figure 4-4 History Record Interface

5 Commissioning

Before powering up the PV system it is important to check the installation for any hazards that may be present. For convenience a commissioning checklist is included in this manual and can be found in the Appendix.

5.1 Mechanical Installation check

- Make sure that the mounting bracket is secure and all screws have been tightened to the specified torque values. (Refer to [3.2_Mechanical Installation](#))
- Confirm all knockouts are sealed and conduit is securely attached to the inverter, creating a water-tight seal.

5.2 Conductor Connections check

- Make sure all conductors are connected to the right terminals and properly labeled.
- The appropriate cable management is important to avoid physical damage. No sharp edges from cable ties exist.
- Check polarity of DC input conductors. The DC Switch should be in the “OFF” position. (Refer to [3.3_Electrical Installation](#))

5.3 Electrical Check

- Make sure that the AC circuit breaker is appropriately sized.
- Test whether the AC voltage is within the normal operating range.
- Confirm the DC open circuit voltage of input strings is less than 1000V. Note: If Tigo TS4-A-F/TS4-F products are installed and in the OFF position, each module will measure 0.6Vdc. Ensure the DC open circuit voltage of input strings will be less than 1000V when power is supplied to the Rapid Shutdown transmitter, if applicable.

5.4 Commissioning Steps

Complete the list above before commissioning the inverter as follows:

1. Turn on the AC circuit breaker.
2. Turn “ON” the external DC switch(s)/circuit breaker(s). Skip these two steps if there are no switches or circuit breakers.
3. Switch the Inverter’s DC Switch to the “ON” position. When the energy supplied by the PV array is sufficient, the LCD screen of inverter will light up. The inverter will then start up with the message “sys checking”.

When the inverter completes “**Initialization**”, the LCD will show the screen as Figure 5-1 below.



Figure 5-1 System Initialization Logo

4. Setting Language. Press **ENT** to access the main menu, select **Setting** and press **ENT**. The password is “1111”, using the arrow keys enter the password and press **ENT** to access the next submenu. Select **System Parameters**, press **ENT**. Scroll to **Setting Language**, press **ENT**. Then select the desired language and press **ENT**.

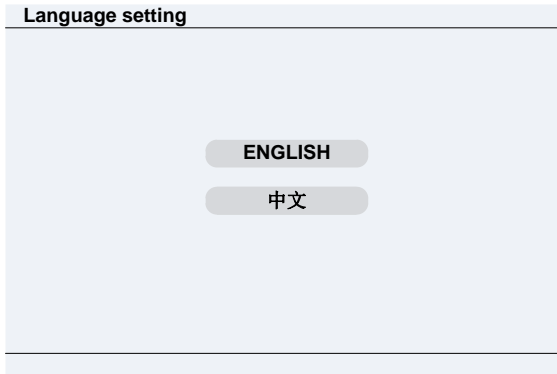

Figure 5-2 Language Setting

5. Set the grid standard. From the previous menu press **ESC** to return to the **System Parameters** menu. If the display had been previously returned to the main menu, follow the steps in (4) to access **System Parameters** again. Select **System Parameters**, press **ENT**. Scroll to **Grid Connection Rule** and press **ENT**.

Use the arrow buttons to move up/down to the required grid standard. Press **ENT** to select the required standard.



INSTRUCTION:

Check with your local utility company before selecting a grid standard. If the inverter is operating with a wrong grid standard, the utility company may cancel the interconnection agreement.

Placing the inverter into operation before the overall system complies with the national rules and safety regulations of the application is not permitted.

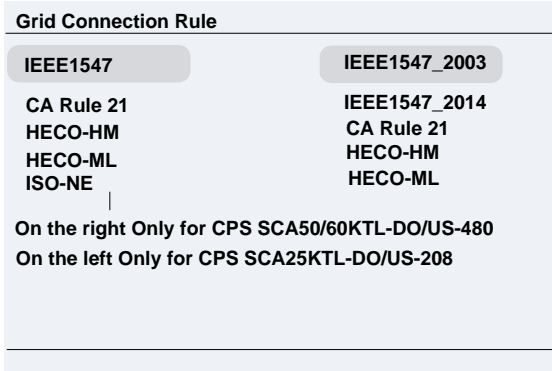

Figure 5-3 Set up Grid Standard

- Setting the Time. From the previous menu, press ESC to return to the System Parameters menu. Select Time and press ENT. Scroll up/down to select the numerical value, then press ENT to go to next option. e.g.: Year to Month, press ESC to go to last option. e.g.: Month to Year. Finally Press the ENT key to confirm the setting. (Press **▲** more than 1 second to go to last position of the number when setting the parameters. e.g: 2008 to 2008. Press **▼** more than 1 second to go to the next position of the number when setting the parameters. e.g: 2008 to 2008.)



Figure 5-4 Time Setting

7. Choose PV Input working mode. The factory default working mode of the DC input connection and MPP Tracker is set for Independent. Contact CPS if parallel mode is required.

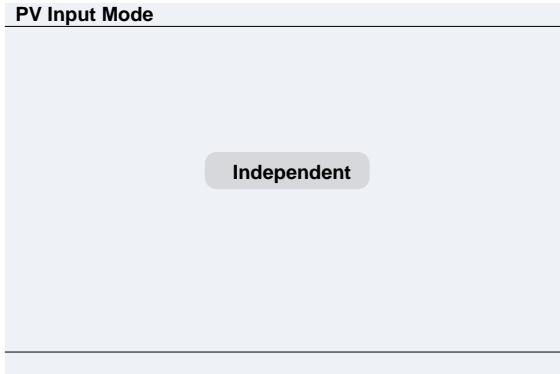

Figure 5-5 Independent Mode Setting

8. Neutral Line Setting. From the previous menu, press **ESC** to return to the **System Parameters** menu. Select **Neutral Line Setting** and press **ENT**. Use the arrow keys to highlight "Yes" or "No" in regard to whether a neutral conductor is present. Press **ENT**.

This setting will allow the inverter to display L-N voltages on the LCD. It will not affect the operation of the inverter.

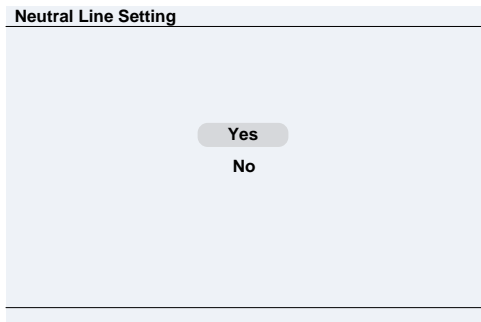

Figure 5-6 Setting the Neutral Line

9. Choosing the communication data. From the previous menu, press ESC to return to the System Parameters menu. Scroll to Communication Setting and press ENT. Select Baud rate and press ENT. The default setting is 9600. Depending on the data acquisition/SCADA system being used, the baud rate may need to be increased or decreased. Scroll up/down to select other speeds and press ENT.

Next, select **Address** and press **ENT**. This designates the inverter address. Each inverter within the Modbus network must have a unique address. Scroll up/down to choose an address for the inverter and press **ENT**. Addresses can be assigned from 1-128. See Figure 5-7.

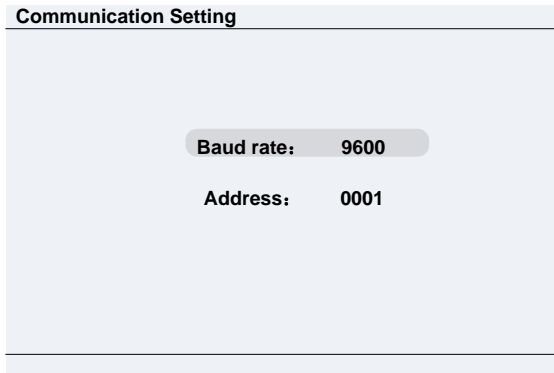

Figure 5-7 Communication Setting

10. Setting the LCD contrast grade. From the previous menu, press ESC to return to System Parameters menu. Select LCD Contrast Setting and press ENT. Using the up/down arrows increase or decrease the contrast to the desired setting. Press ENT to accept the changes.
11. When the LCD screen shows the normal operation status (Figure 5-8) and the "RUN" light on the LED panel is illuminated, this is an indication that the grid connection and power generation are successful.

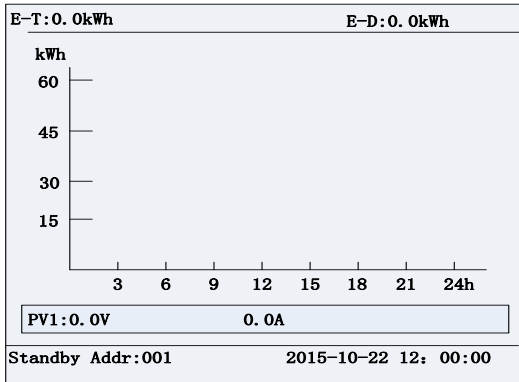

Figure 5-8 Normal Operation Status

- If the inverter fails to operate normally, the “FAULT” light will illuminate and the fault menu will be displayed. Select Current Error and press ENT to access the current faults the inverter has recorded. This information will show on the LCD screen as shown in the Figure 5-9.

Current Error		
Date	Time	Fault
2015/10/22	12:20:08	ArcboardErr
2015/10/22	12:20:08	Fault0040
2015/10/22	12:20:08	Fault0040
2015/10/22	12:20:08	Fault0040
2015/10/22	12:20:08	Fault0040

P1/1

Figure 5-9 Fault Information Interface

6 Main Menu and Operation

LCD screen displays “default indication interface” when the inverter is in operation mode. Press ESC in this interface to escape the default interface and Press ENT to access the main operation interface. The main operation interface is shown in Figure 6-1.

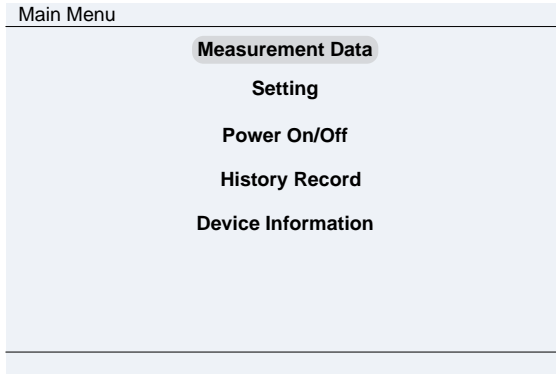

Figure 6-1 Main Menu on the LCD Screen

The main menu of the LCD screen has 5 menus, “**Measurement Data**”, “**Setting**”, “**Power ON/OFF**”, “**History Record**”, and “**Device Information**”. The users may select options by moving the cursor up/down with \uparrow and \downarrow , and then press the **ENT** key to confirm the selection. The users can return to the default indication interface by pressing the **ESC** key.

6.1 Measurement Data

When **Measurement Data** is selected in the main screen, pressing the **ENT** key opens the operation information as shown in Figure 6-2. Check the information by pressing \uparrow and \downarrow . Return to the previous menu by pressing the **ESC** key.

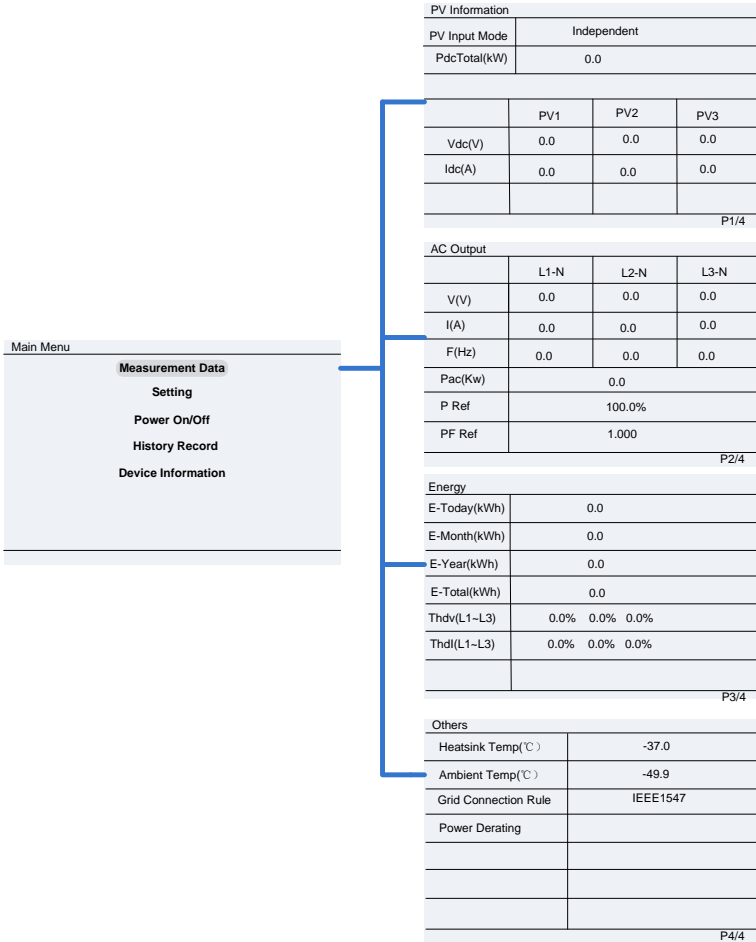



Figure 6-2 Operation Information

6.2 Setting

Move the cursor to Setting in the main interface. Press the ENT key to be prompted for the password: “1111” as shown in Figure 6-3. Enter the password number by pressing  and , selecting the numeral, and pressing the ENT key to input and proceed to the next digit of the password



number. Once all four digits are entered, press the ENT key to confirm the password or Press the ESC key to go back to Setting.



Figure 6-3 Input Password Number

The Setting menu contains eight submenus: System Parameters, Control Command, Protection Parameters, LVRT/HVRT Setup, Power Derating Setting, Reactive Power Derating Setup, ARC Parameters, and Other Parameters.

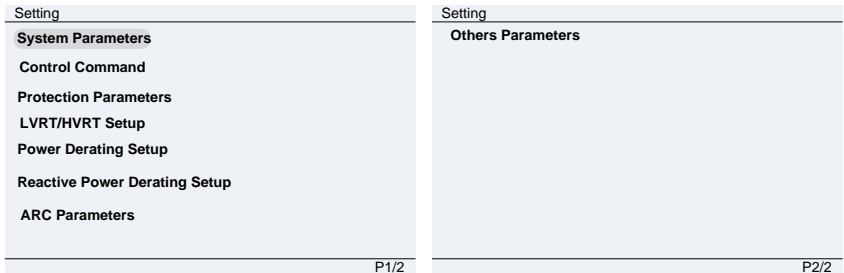

Figure 6-4 System Setup Menu and Submenus Overview

6.2.1 System Parameters

The System Parameter selection contains nine submenus.

1. **Language Setting.** Two languages, i.e. Chinese and English are available in Language menu.

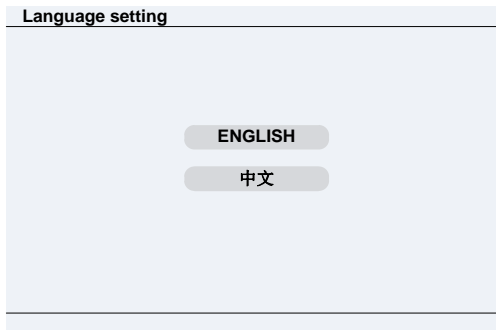
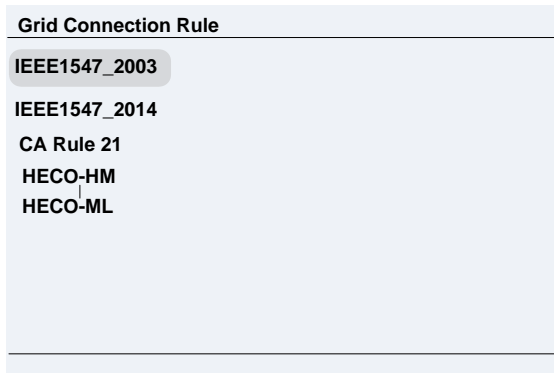
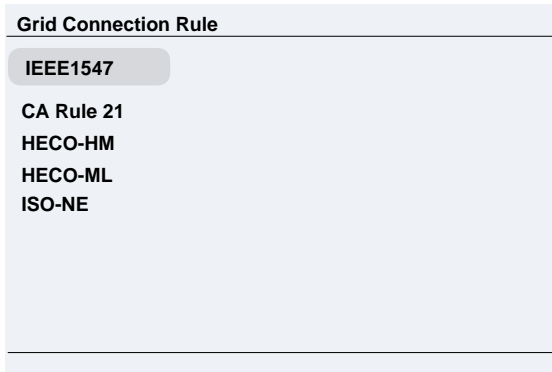

Figure 6-5 Language Setting

2. **Grid Connection Rule.** Multiple grid standards are available. Press \uparrow and \downarrow to select the corresponding grid standard required for the installation and press the **ENT** key.



Only for CPS SCA25KTL-DO/US-208



Only for CPS SCA50/60KTL-DO/US-480

Figure 6-6 Setting Grid Rule



INSTRUCTION:

Please check with your local electric utility supply company before selecting a grid standard. If the inverter is operated with an incorrect grid standard, the electric utility supply company may cancel the interconnection agreement.

Placing the inverter into operation before the overall system complies with the national codes, rules and safety regulations of the application is also not permitted.

-
- 3. PV Input Mode.** This allows the user to read the inverter working mode as "**Independent**" or "**Parallel**" mode. The inverter is factory set in Independent mode. If this needs to be set to Parallel contact CPS to have this setting changed.
 - 4. Neutral Line Setting.** This option allows the user to select "Yes/No" if a neutral conductor has been connected to the inverter. This setting

does not affect the operation of the inverter. When a neutral is installed and “Yes” is selected, the inverter will display L-N measurements.

5. **Communication Setting.** This interface is used to set the Modbus ID and Baud rate for communication. More information on this is found in the “Commissioning” section.
6. **Time.** Press \uparrow or \downarrow to select the numerical value, then press **ENT** to go to next option. e.g.: Year to Month, press **ESC** to go to last option. e.g.: Month to Year. Finally Press the **ENT** key to confirm the setting. Press \uparrow more than 1 second to go to last position of the number when setting the parameters. e.g: 2008 to 2008. Press \downarrow more than 1 second to go to the next position of the number when setting the parameters. e.g: 2008 to 2008.
7. **LCD Contrast Setting.** Press \uparrow or \downarrow to increase/decrease the LCD contrast. Press **ENT** to accept changes.

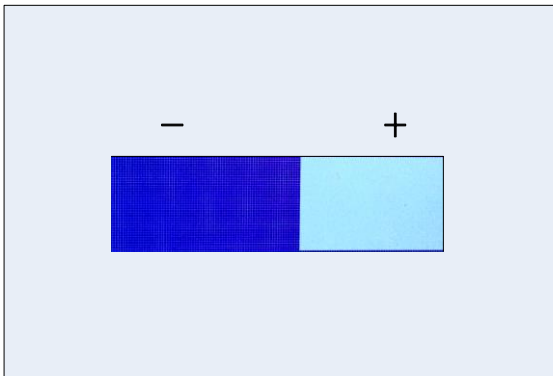

Figure 6-7 LCD Contrast Grade Setting

6.2.2 Control Command

There are five submenus in the “**Control Command**” menu:

Control Command	Control Command		
	PV1	PV2	PV3
Force Restart			
Factory Defaults			
ARC Detect	0	0	0
ARC Clear	0.0	0.0	0.0
	0.0	0.0	0.0
	0.0	0.0	0.0
P1/2	MPPT Scan		P2/2

Figure 6-8 Control Command Setting

1. **Force Restart.** If a fault shutdown happens, a severe fault may have occurred inside the inverter. The user can perform a force reboot for one time in this menu if the user needs to restart the inverter.



INSTRUCTION:

Force Restart is effective only when the faults “IntFault0010~0150” in the troubleshooting table occur. The inverter may restore to normal operation automatically if alarm or protection faults occur. This function will not respond when the inverter is in operation mode and a “FaultOperated” alarm interface will be indicated.

2. **Factory Default.** The manufacturer’s parameter default values can be restored when the inverter is not in operation mode. Otherwise “Fault Operated” will be reported.
3. **ARC Detect.** Manually begin an arc-fault test. The inverter will cease power production and test ARC.

Arcing check and protection is mainly divided into two parts, the Arcing check board is responsible for whether there is Arcing in line, and transfer an Arc protection signal to the DSP in the dominating control

board. The control board DSP is responsible for disconnecting the inverter from the grid after receiving the Arc protection signal to ensure safety. The Arc board failure will cause 'arc board err' shown on the LCD and it will not connect to the grid until the arc board is OK. If there is an Arc fault, the LCD displays the fault which can only be cleared manually.

4. **ARC Clear.** Manually clear the ARC fault. Move the cursor to this menu, and press ENT. The operation result will appear on the LCD, ie. "Succeed" or "Failed". Complete this action after checking the PV system for potential arcs and taking corrective action.

5. **MPPT Scan.** Manually execute the MPPT scan. Move the cursor to this item and press the ENT key to initiate the scanning. The LCD screen will skip to normal operation interface if the MPPT scanning succeeds or remain on the MPPT Scan menu interface if the scanning fails.

The factory default setting for "MPPTScan" is set to Enabled, yet can also be set to Disabled. When the MPPT scan function is enabled, the default scan period is every 60 minutes. The inverter will scan the maximum power point in the MPPT range, according to the following condition:

While in Parallel mode, the total input power is lower than 90% of the active power.

While in Independent mode (3 MPPTs), the input power must be lower than 75% of the rated power for each MPPT tracker.

Once this MPPT scan function is activated on LCD, it will search the maximum power point at a voltage step of 5V in the MPPT range for full load and retrieve the maximum power point.



6.2.3 Protect Parameters

This interface is used to display and set the Protect parameters of the AC grid voltage, frequency and recovery, etc, as shown in Figure 6-9.

Setting System Parameters Control Command Protection Parameters LVRT/THVRT Setup Power Derating Setup Reactive Power Derating Setup ARC Parameters	Grid Over Voltage Protection			Grid Under Voltage Protection		
	GridVolMax1	110.00%	Enable	GridVolMin1	88.00%	Enable
	VolMaxTripT1(S)	1.00		VolMinTripT1(S)	2.00	
	GridVolMax2	120.00%	Enable	GridVolMin2	60.00%	Enable
	VolMaxTripT2(S)	0.16		VolMinTripT2(S)	1.00	
	GridVolMax3	120.00%	Disable	GridVolMin3	45.00%	Enable
	VolMaxTripT3(S)	0.16		VolMinTripT3(S)	0.16	
	P1/7			P2/7		
	Grid Over Frequency Protection			Grid Under Frequency Protection		
	GridFrqMax1(Hz)	60.5	Enable	GridFrqMin1(Hz)	59.5	Enable
	FrqMaxTripT1(S)	2.00		FrqMinTripT1(S)	2.00	
	GridFrqMax2(Hz)	62	Enable	GridFrqMin2(Hz)	57.0	Enable
	GridMaxTripT2(S)	0.16		GridMinTripT2(S)	0.16	
	GridFrqMax3(Hz)	62	Disable	GridFrqMin3(Hz)	57.0	Disable
	FrqMaxTripT3(S)	0.16		FrqMinTripT3(S)	0.16	
	P3/7			P4/7		
	Grid Recovery			Voltage Moving Average		
	VolMax	107.92%		VolMax	110.00%	Disable
VolMin	90.08%	MaxTripT(S)		600.00		
VolRecoveryT(S)	300.00		VolMin	88.00%	Disable	
FrqMax(Hz)	60.3		MinTripT(S)	600.00		
FrqMin(Hz)	59.8					
FrqRecoveryT(S)	300.00					
P5/7			P6/7			
Grid Voltage Balance						
GridVolUnbalance	10.00%	Disable				
PhaseLoseCoeff	3.0%					
PhaseLoseRovCoeff	2.0%	Disable				
PhaseLoseVUnbalance	10.00%					
Phase-PETripVolt	45.00%	Disable				
Phase-PERovVolt	35.00%					
P7/7						

Figure 6-9 Protection Parameter Settings

There are 7 pages of parameters displayed. Navigate the parameters by pressing \uparrow and \downarrow . Then press **ENT** to access the highlighted selection. Change the parameter value by pressing \uparrow and \downarrow then **ENT** to confirm the parameter setting. The LCD will display new parameters if the setting is successful, otherwise the old parameters will remain displayed on the LCD.



Table 6-1 Protection Parameters (IEEE1547 / Rule21 and ISO-NE)

Only for CPS SCA50/60KTL-DO/US-480

Grid Voltage Protection		Setting Range								
Parameter name	Description (Threshold Value of)	IEEE1547			Rule21			ISO-NE		
		Min	Default	Max	Min	Default	Max	Min	Default	Max
GridVoltMax1	Level 1 Max. grid voltage	100	110	135	100	110	135	100	110.00	135
VoltMaxTripTime1(S)	Level 1 Max. grid trip voltage	0	1	655	0	12.5	655	0	2.00	655
GridVoltMax2	Level 2 Max. grid voltage	100	120	135	100	120	135	100	120.00	135
VoltMaxTripTime2(S)	Level 2 Max. grid trip voltage	0	0.16	655	0	0.16	655	0	0.16	655
GridVoltMax3	Level 3 Max. grid voltage	100	120	135	100	120	135	100	120.00	135
VoltMaxTripTime3(S)	Level 3 Max. grid trip voltage	0	0.16	655	0	0.16	655	0	0.16	655
GridVoltMin1	Level 1 Min. grid voltage	30	88	100	30	88	100	30	88.00	100
VoltMinTripTime1(S)	Level 1 Min. grid trip voltage	0	2	655	0	20.5	655	0	2.00	655
GridVoltMin2	Level 2 Min. grid voltage	30	60	100	30	70	100	30	50.00	100
VoltMinTripTime2(S)	Level 2 Min. grid trip voltage	0	1	655	0	10.5	655	0	1.10	655
GridVoltMin3	Level 3 Min. grid voltage	30	45	100	30	50	100	30	50.00	100
VoltMinTripTime3(S)	Level 3 Min. grid trip voltage	0	0.16	655	0	1.5	655	0	1.10	655

Table 6-2 Protection Parameters (IEEE1547 and Rule21)

Only for CPS SCA25KTL-DO-US-208

Grid Voltage Protection		Setting Range					
Parameter name	Description (Threshold Value of)	IEEE1547			Rule21		
		Min	Default	Max	Min	Default	Max
GridVoltMax1(%)	Level 1 Max. grid voltage	100.00	110.00	135.00	100.00	110.00	135.00
VoltMaxTripTime1(S)	Level 1 Max. grid trip voltage	0.00	1.00	655.00	0.00	1.00	655.00
GridVoltMax2(%)	Level 2 Max. grid voltage	100.00	120.00	135.00	100.00	120.00	135.00
VoltMaxTripTime2(S)	Level 2 Max. grid trip voltage	0.00	0.16	655.00	0.00	0.16	655.00
GridVoltMax3(%)	Level 3 Max. grid voltage	100.00	120.00	135.00	100.00	120.00	135.00
VoltMaxTripTime3(S)	Level 3 Max. grid trip voltage	0.00	0.16	655.00	0.00	0.16	655.00
GridVoltMin1 (%)	Level 1 Min. grid voltage	30.00	88.00	100.00	30.00	88.00	100.00
VoltMinTripTime1(S)	Level 1 Min. grid trip voltage	0.00	2.00	655.00	0.00	2.00	655.00
GridVoltMin2 (%)	Level 2 Min. grid voltage	30.00	60.00	100.00	30.00	60.00	100.00
VoltMinTripTime2(S)	Level 2 Min. grid trip voltage	0.00	1.00	655.00	0.00	1.00	655.00
GridVoltMin3 (%)	Level 3 Min. grid voltage	30.00	45.00	100.00	30.00	45.00	100.00
VoltMinTripTime3(S)	Level 3 Min. grid trip voltage	0.00	0.16	655.00	0.00	0.16	655.00



Table 6-3 Protection Parameters (IEEE1547 /Rule21 and ISO-NE) Cont'd

Only for CPS SCA50/60KTL-DO/US-480

Grid Frequency Protection		Setting Range								
Parameter name	Description	IEEE1547			Rule21			ISO-NE		
		Min	Default	Max	Min	Default	Max	Min	Default	Max
GridFrqMax1	Protection threshold value of Level 1 Max. grid frequency	60	60.50	65	60	60.5	65	60	61.2	65
FrqMaxTripT1(S)	Trip time of Level 1 Max. grid frequency	0	2	655	0	299.5	655	0	299.50	655
GridFrqMax2	Protection threshold value of Level 2 Max. grid frequency	60	62	65	60	62	65	60	62.0	65
FrqMaxTripT2(S)	Trip time of Level 2 Max. grid frequency	0	0.16	655	0	0.16	655	0	0.16	655
GridFrqMax3	Protection threshold value of Level 3 Max. grid frequency	60	62	65	60	62	65	60	62.0	65
FrqMaxTripT3(S)	Trip time of Level 3 Max. grid frequency	0	0.16	655	0	0.16	655	0	0.16	655
GridFrqMin1	Protection threshold value of Level 1 Min. grid frequency	54	59.5	60	54	58.5	60	54	58.5	60
FrqMinTripT1 (S)	Trip time of Level 1 Min. grid frequency	0	2	655	0	299.5	655	0	299.5	655
GridFrqMin2	Protection threshold value of Level 2 Min. grid frequency	54	57	60	54	57	60	54	56.5	60
FrqMinTripT2 (S)	Trip time of Level 2 Min. grid frequency	0	0.16	655	0	0.16	655	0	0.16	655
GridFrqMin3	Protection threshold value of Level 3 Min. grid frequency	54	57	60	54	57	60	54	56.5	60
FrqMinTripT3 (S)	Trip time of Level 3 Min. grid frequency	0	0.16	655	0	0.16	655	0	0.16	655

Table 6-4 Protection Parameters (IEEE1547 and Rule21) Cont'd

Only for CPS SCA25KTL-DO-US-208

Grid Frequency Protection		Setting Range					
Parameter name	Description	IEEE1547			Rule21		
		Min	Default	Max	Min	Default	Max
GridFrqMax1(%)	Protection threshold value of Level 1 Max. grid frequency	60.00	60.50	65.00	60.00	60.50	65.00
FrqMaxTripT1(S)	Trip time of Level 1 Max. grid frequency	0.00	2	655.00	0.00	2.00	655.00
GridFrqMax2(%)	Protection threshold value of Level 2 Max. grid frequency	60.00	62.00	65.00	60.00	62.00	65.00
FrqMaxTripT2(S)	Trip time of Level 2 Max. grid frequency	0.00	0.16	655.00	0.00	0.16	655.00
GridFrqMax3(%)	Protection threshold value of Level 3 Max. grid frequency	60.00	62.00	65.00	60.00	62.00	65.00
FrqMaxTripT3(S)	Trip time of Level 3 Max. grid frequency	0.00	0.16	655.00	0.00	0.16	655.00
GridFrqMin1(%)	Protection threshold value of Level 1 Min. grid frequency	48.00	59.50	60.00	48.00	59.50	60.00
FrqMinTripT1 (S)	Trip time of Level 1 Min. grid frequency	0.00	2.00	655.00	0.00	2.00	655.00
GridFrqMin2(%)	Protection threshold value of Level 2 Min. grid frequency	48.00	57.00	60.00	48.00	57.00	60.00
FrqMinTripT2 (S)	Trip time of Level 2 Min. grid frequency	0.00	0.16	655.00	0.00	0.16	655.00
GridFrqMin3(%)	Protection threshold value of Level 3 Min. grid frequency	48.00	57.00	60.00	48.00	57.00	60.00
FrqMinTripT3 (S)	Trip time of Level 3 Min. grid frequency	0.00	0.16	655.00	0.00	0.16	655.00



Table 6-5 Protection Parameters (IEEE1547 /Rule21 and ISO-NE) Cont'd

Only for CPS SCA50/60KTL-DO/US-480

Grid Recovery		Setting Range								
Parameter name	Description	IEEE1547			Rule21			ISO-NE		
		Min	Default	Max	Min	Default	Max	Min	Default	Max
VoltMax	Recovery Max threshold of grid voltage protection	80	107.92	135	80	107.99	135	80	108.00	135
VoltMin	Recovery Min threshold of grid voltage protection	20	90.08	100	20	90	100	20	90.00	100
VolRecoveryT(S)	Recovery time of grid voltage protection	0	300	655	0	300	655	0	300.00	655
FrqMax (Hz)	Recovery Max threshold of grid Frequency protection	54	60.30	66	54	60.4	66	54	61.0	66
FrqMin (Hz)	Recovery Min threshold of grid Frequency protection	54	59.8	60	54	58.6	60	54	58.7	60
FrqRecoveryT (S)	Recovery time of grid frequency protection	0	300	655	0	300	655	0	300.00	655
Grid Voltage Moving Average										
VoltMax	The Max grid voltage of moving average filter	100	110	135	100	110	135	100	110	135
MaxTripT(s)	The trip time of the Max grid voltage of moving average filter	0	600	655	0	600	655	0	600	655
VoltMin	The Min grid voltage of moving average filter	80	88	100	80	88	100	80	88	100
MinTripT(s)	The trip time of the Min grid voltage of moving average filter	0	600	655	0	600	655	0	600	655

Grid Voltage Balance

GridVolBalance	Threshold value of grid voltage imbalance	0.01	10	10	0.01	10	10	0.01	10	10
PhaseLoseCoeff (%)	PhaseLoseCoeff	0.5	3.0	30.0	0.5	3.0	30.0	0.5	3.0	30.0
PhaseLoseRcvCoeff (%)	PhaseLoseRcvCoeff	0.5	2.0	30.0	0.5	2.0	30.0	0.5	2.0	30.0
PhaseLoseVUnbalance (%)	PhaseLose Voltage Unbalance	0.01	10.00	100.00	0.01	10.00	100.00	0.01	10.00	100.00
Phase-PETripVolt (%)	The trip voltage of Phase-PE	0.01	45.00	100.00	0.01	45.00	100.00	0.01	45.00	100.00
Phase-PERcvVolt (%)	The recovery voltage of Phase-PE	0.01	35.00	100.00	0.01	35.00	100.00	0.01	35.00	100.00

Table 6-6 Protection Parameters (IEEE1547 and Rule21) Cont'd

Only for CPS SCA25KTL-DO-US-208

Grid Recovery		Setting Range					
Parameter name	Description	IEEE1547			Rule21		
		Min	Default	Max	Min	Default	Max
VoltMax(%)	Recovery Max threshold of grid voltage protection	80.00	108.00	135.00	80.00	108.00	135.00
VoltMin(%)	Recovery Min threshold of grid voltage protection	20.00	90.00	100.00	20.00	90.00	100.00
VolRecoveryT(S)	Recovery time of grid voltage protection	0.00	300.00	655.00	0.00	300.00	655.00
FrqMax (Hz)	Recovery Max threshold of grid Frequency protection	54.0	60.30	66.00	54.0	60.30	66.0
FrqMin (Hz)	Recovery Min threshold of grid Frequency protection	48.00	59.80	60.00	48.00	59.80	60.00
FrqRecoveryT (S)	Recovery time of grid frequency protection	0.00	300.00	655.00	0.00	300.00	655.00
VoltMax(%)	The Max grid voltage of moving average filter	100.00	110.00	135.00	100.00	110.00	135.00
MaxTripT(s)	The trip time of the Max grid voltage of moving average filter	0.00	600.00	655.00	0.00	600.00	655.00
VoltMin(%)	The Min grid voltage of moving average filter	80.00	88.00	100.00	80.00	88.00	100.00
MinTripT(s)	The trip time of the Min grid voltage of moving average filter	0.00	600.00	655.00	0.00	600.00	655.00
GridVolBalance(%)	Threshold value of grid voltage	0.01	10.00	10.00	0.01	10.00	10.00

	imbalance						
PhaseLoseCoeff (%)	PhaseLoseCoeff	0.5	3.0	30.0	0.5	3.0	30.0
PhaseLoseRcvCoeff (%)	PhaseLoseRcvCoeff	0.5	2.0	30.0	0.5	2.0	30.0
PhaseLoseVUnbalance (%)	PhaseLose Voltage Unbalance	0.01	10.00	100.00	0.01	10.00	100.00
Phase-PETripVolt (%)	The trip voltage of Phase-PE	0.01	45.00	100.00	0.01	45.00	100.00
Phase-PERcvVolt (%)	The recovery voltage of Phase-PE	0.01	35.00	100.00	0.01	35.00	100.00

6.2.4 LVRT/HVRT Parameters

LVRT/HVRT™ is used to set the LVRT and HVRT parameters. Move the cursor to this item and press the **ENT** key to set the parameters. There are 7 pages of LVRT/HVRT parameter settings. These can be changed in the menu tree or by the LVRT (Figure 6-11) and HVRT (Figure 6-12) graphs.

Setting System Parameters Control Command Protection Parameters LVRT/HVRT Setup Power Derating Setup Reactive Power Derating Setup ARC Parameters	LVRT Curve		LVRT Curve		LVRT Curve	
	LVRTVol1	0.00%	LVRTVol4	45.00%	LVRTVol7	83.00%
	LVRTTime1(s)	0.00	LVRTTime4(s)	10.50	LVRTTime7(s)	20.50
	LVRTVol2	0.00%	LVRTVol5	65.00%	LVRTVol8	83.00%
	LVRTTime2(s)	1.20	LVRTTime5(s)	10.50	LVRTTime8(s)	20.50
	LVRTVol3	45.00%	LVRTVol6	65.00%		
	LVRTTime3(s)	1.20	LVRTTime6(s)	20.50		
		P1/7		P2/7		P3/7
		HVRT Curve		HVRT Curve		HVRT Curve
HVRTVol1	125.00%	HVRTVol4	124.00%	HVRTVol7	115.00%	
HVRTTime1(s)	0.00	HVRTTime4(s)	12.50	HVRTTime7(s)	12.50	
HVRTVol2	125.00%	HVRTVol5	115.00%	HVRTVol8	115.00%	
HVRTTime2(s)	0.80	HVRTTime5(s)	12.50	HVRTTime8(s)	12.50	
HVRTVol3	124.00%	HVRTVol6	115.00%			
HVRTTime3(s)	0.80	HVRTTime6(s)	12.50			
	P4/7		P5/7		P6/7	
	LVRT and HVRT Control					
LVRTModeSetting	0					
LVRTTripVolt	80.0%					
LVRTPosReactive	150.0%					
LVRTNegReactive	200.0%					
HVRTModeSetting	0					
HVRTTripVolt	110.0%					
	P7/7					

Figure 6-10 L/HVRT Parameter Settings

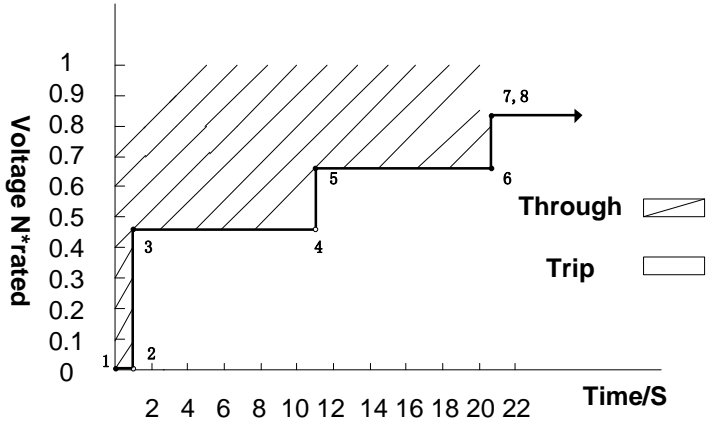

Figure 6-11 The LVRT Curve

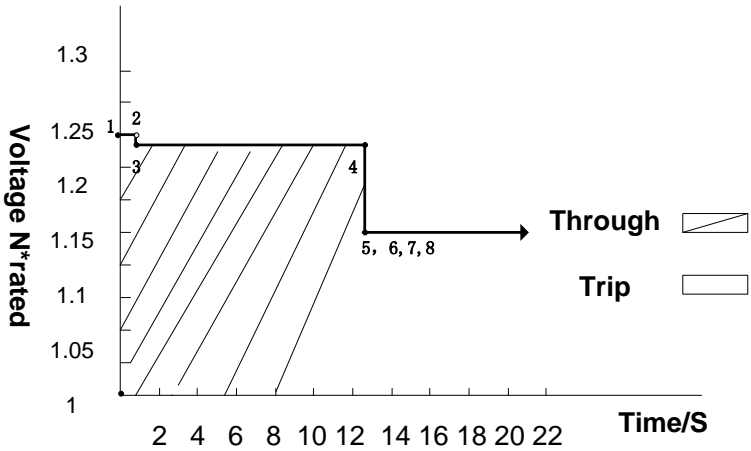

Figure 6-12 The HVRT Curve

Table 6-7 LVRT Parameters (IEEE1547 / Rule21 and ISO-NE)

Only for CPS SCA50/60KTL-DO/US-480

LVRT		Setting Range								
Parameter Name	Description	IEEE1547			Rule21			ISO-NE		
		Min	Default	Max	Min	Default	Max	Min	Default	Max
LVRTVolt (1,2)	Threshold value of Low voltage ride through (1 st & 2 nd point)	0	0	100	0	0	100	0	0	100
		0	0	100	0	0	100	0	0	100
LVRTTime (1,2)	Time of Level Low voltage ride through (1 st & 2 nd point)	0	0	655	0	0	655	0	0	655
		0	1.20	655	0	1.20	655	0	0.16	655
LVRTVolt (3,4)	Threshold value of Low voltage ride through (3 rd & 4 th point)	0	45	100	0	50	100	0	30	100
		0	45	100	0	50	100	0	45	100
LVRTTime (3,4)	Time of Level Low voltage ride through (3 rd & 4 th point)	0	1.20	655	0	1.20	655	0	0.16	655
		0	10.50	655	0	10.50	655	0	0.21	655
LVRTVolt (5,6)	Threshold value of Low voltage ride through (5 th & 6 th point)	0	65	100	0	70	100	0	45	100
		0	65	100	0	70	100	0	65	100
LVRTTime (5,6)	Time of Level Low voltage ride through (5 th & 6 th point)	0	10.50	655	0	10.50	655	0	0.37	655
		0	20.50	655	0	20.50	655	0	0.37	655
LVRTVolt (7,8)	Threshold value of Low voltage ride through (7 th & 8 th point)	0	83	100	0	88	100	0	65	100
		0	83	100	0	88	100	0	88	100
LVRTTime (7,8)	Time of Level Low voltage ride through (7 th & 8 th point)	0	20.5	655	0	20.5	655	0	3.05	655
		0	20.5	655	0	20.5	655	0	3.25	655

Table 6-8 LVRT Parameters (IEEE1547 and Rule21)

Only for CPS SCA25KTL-DO-US-208

LVRT		Setting Range					
Parameter Name	Description	IEEE1547			Rule21		
		Min	Default	Max	Min	Default	Max
LVRTVolt (1,2) (%)	Threshold value of Low voltage ride through (1 st & 2 nd point)	0.00	0.00	100.00	0.00	0.00	100.00
		0.00	0.00	100.00	0.00	0.00	100.00
LVRTTime (1,2) (S)	Time of Level Low voltage ride through (1 st & 2 nd point)	0.00	0.00	655.00	0.00	0.00	655.00
		0.00	1.20	655.00	0.00	1.20	655.00
LVRTVolt (3,4) (%)	Threshold value of Low voltage ride through (3 rd & 4 th point)	0.00	45.00	100.00	0.00	45.00	100.00
		0.00	45.00	100.00	0.00	45.00	100.00
LVRTTime (3,4) (S)	Time of Level Low voltage ride through (3 rd & 4 th point)	0.00	1.20	655.00	0.00	1.20	655.00
		0.00	10.50	655.00	0.00	10.50	655.00
LVRTVolt (5,6) (%)	Threshold value of Low voltage ride through (5 th & 6 th point)	0.00	65.00	100.00	0.00	65.00	100.00
		0.00	65.00	100.00	0.00	65.00	100.00
LVRTTime (5,6) (S)	Time of Level Low voltage ride through (5 th & 6 th point)	0.00	10.50	655.00	0.00	10.50	655.00
		0.00	20.50	655.00	0.00	20.50	655.00
LVRTVolt (7,8) (%)	Threshold value of Low voltage ride through (7 th & 8 th point)	0.00	83.00	100.00	0.00	83.00	100.00
		0.00	83.00	100.00	0.00	83.00	100.00
LVRTTime (7,8) (S)	Time of Level Low voltage ride through (7 th & 8 th point)	0.00	20.50	655.00	0.00	20.50	655.00
		0.00	20.50	655.00	0.00	20.50	655.00

Table 6-9 HVRT Parameters (IEEE5147 / Rule21 and ISO-NE)

Only for CPS SCA50/60KTL-DO/US-480

HVRT		Setting Range								
Parameter Name	Description	IEEE1547			Rule21			ISO-NE		
		Min	Default	Max	Min	Default	Max	Min	Default	Max
HVRTVolt (1,2)	Threshold value of high voltage ride through (1 st & 2 nd point)	100	125	135	100	125	135	100	120	135
		100	125	135	100	125	135	100	120	135
HVRTTime (1,2)	Time of Level high voltage ride through (1 st & 2 nd point)	0	0	655	0	0	655	0	0	655
		0	0.80	655	0	0.11	655	0	0.16	655
HVRTVolt (3,4)	Threshold value of high voltage ride through (3 rd & 4 th point)	100	124	135	100	120	135	100	120	135
		100	124	135	100	120	135	100	117.5	135
HVRTTime (3,4)	Time of Level high voltage ride through (3 rd & 4 th point)	0	0.80	655	0	0.11	655	0	0.25	655
		0	12.50	655	0	12.50	655	0	0.25	655
HVRTVolt (5,6)	Threshold value of high voltage ride through (5 th & 6 th point)	100	115	135	0	110	135	0	117.5	135
		100	115	135	0	110	135	0	115.0	135
HVRTTime (5,6)	Time of Level high voltage ride through (5 th & 6 th point)	0	12.50	655	0	12.50	655	0	0.55	655
		0	12.50	655	0	12.50	655	0	0.55	655
HVRTVolt (7,8)	Threshold value of high voltage ride through (7 th & 8 th point)	100	115	135	100	110	135	100	115	135
		100	115	135	100	110	135	100	110	135
HVRTTime (7,8)	Time of Level high voltage ride through (7 th & 8 th point)	0	12.50	655	0	12.50	655	0	10.50	655
		0	12.50	655	0	12.50	655	0	10.50	655

Table 6-10 HVRT Parameters (IEEE5147 and Rule21)
Only for CPS SCA25KTL-DO-US-208

HVRT		Setting Range					
Parameter Name	Description	IEEE1547			Rule21		
		Min	Default	Max	Min	Default	Max
HVRTVolt (1,2) (%)	Threshold value of high voltage ride through (1 st & 2 nd point)	100.00	125.00	135.00	100.00	125.00	135.00
		100.00	125.00	135.00	100.00	125.00	135.00
HVRTTime (1,2) (S)	Time of Level high voltage ride through (1 st & 2 nd point)	0.00	0.00	655.00	0.00	0.00	655.00
		0.00	0.80	655.00	0.00	0.80	655.00
HVRTVolt (3,4) (%)	Threshold value of high voltage ride through (3 rd & 4 th point)	100.00	124.00	135.00	100.00	124.00	135.00
		100.00	124.00	135.00	100.00	124.00	135.00
HVRTTime (3,4) (S)	Time of Level high voltage ride through (3 rd & 4 th point)	0.00	0.80	655.00	0.00	0.80	655.00
		0.00	12.50	655.00	0.00	12.50	655.00
HVRTVolt (5,6) (%)	Threshold value of high voltage ride through (5 th & 6 th point)	100.00	115.00	135.00	100.00	115.00	135.00
		100.00	115.00	135.00	100.00	115.00	135.00
HVRTTime (5,6) (S)	Time of Level high voltage ride through (5 th & 6 th point)	0.00	12.50	655.00	0.00	12.50	655.00
		0.00	12.50	655.00	0.00	12.50	655.00
HVRTVolt (7,8) (%)	Threshold value of high voltage ride through (7 th & 8 th point)	100.00	115.00	135.00	100.00	115.00	135.00
		100.00	115.00	135.00	100.00	115.00	135.00
HVRTTime (7,8) (S)	Time of Level high voltage ride through (7 th & 8 th point)	0.00	12.50	655.00	0.00	12.50	655.00
		0.00	12.50	655.00	0.00	12.50	655.00

Table 6-11 LVRT and HVRT Parameters (IEEE5147 / Rule21 and ISO-NE)

Only for CPS SCA50/60KTL-DO/US-480

Grid Frequency Protection		Setting Range								
Parameter Name	Description	IEEE1547			Rule21			ISO-NE		
		Min	Default	Max	Min	Default	Max	Min	Default	Max
LVRTModeSetting	0: Disable 1: Enable, no reactive power output 2: Enable, reactive power output	0	0	2	0	2	2	0	2	2
LVRTTripVolt	Threshold value of LOW voltage trip	70	80	100	70	88	100	70	88	100
LVRTPstReactive1	The factor LVRT Positive Reactive Current	0	150	300	0	150	300	0	150	300
LVRTNegReactive1	The factor LVRT Negative Reactive Current	0	200	300	0	200	300	0	200	300
HVRTModeSetting	0: Disable 1: Enable, no reactive power output 2: Enable, reactive power output	0	0	2	0	2	2	0	1	2
HVRTTripVolt	Threshold value of HIGH voltage trip	100	110	135	100	110	135	100	110	135

Table 6-12 LVRT and HVRT Parameters (IEEE5147 and Rule21)

Only for CPS SCA25KTL-DO-US-208

Grid Frequency Protection		Setting Range					
Parameter Name	Description	IEEE1547			Rule21		
		Min	Default	Max	Min	Default	Max
LVRTModeSetting	0: Disable 1: Enable, no reactive power output 2: Enable, reactive power output	0	0	2	0	0	2
LVRTTripVoltage (%)	Threshold value of LOW voltage trip	70.0	80.0	100.0	70.0	80.0	100.0
LVRTPositiveReactive1 (%)	The factor LVRT Positive Reactive Current	0.0	150.0	300.0	0.0	150.0	300.0
LVRTNegativeReactive1 (%)	The factor LVRT Negative Reactive Current	0.0	200.0	300.0	0.0	200.0	300.0
HVRTModeSetting	0: Disable 1: Enable, no reactive power output 2: Enable, reactive power output	0	0	2	0	0	2
HVRTTripVoltage (%)	Threshold value of HIGH voltage trip	100.0	110.0	135.0	100.0	110.0	135.0

6.2.5 Power Derating Setup

“Power Derating Setup” menu is used to set the active power derating parameters including Active Power Derating, Over frequency derating, Low frequency derating, High temperature frequency derating, etc. The parameters are shown in Figure 6-13.



Table 6-13 Power Derating Setup

Only for CPS SCA50/60KTL-DO/US-480

Grid Over Frequency Derating		Setting Range								
Parameter Name LCD Display	Description	IEEE1547			Rule21			ISO-NE		
		Min	Default	Max	Min	Default	Max	Min	Default	Max
VwcurveV1	Grid overvoltage derating starting voltage V1	105	106	109	105	106	109	105	106	109
VwcurveP1	Grid overvoltage derating starting power P1	0	100	100	0	100	100	0	100	100
VwcurveV2	Grid overvoltage derating end voltage V2	106	110	110	106	110	110	106	110	110
VwcurveP2	Grid overvoltage derating end power P2	0	0	100	0	0	100	0	0	100
OpenloopRespT	Open loop response time	0.5	10	90	0.5	10	90	0.5	10	90
Grid Over Frequency Derating										
OvrFrqMin (Hz)	The trigger frequency of Over Frequency derating	54	60.50	72	54	60.10	66	54	60.5	66
OvrFrqMax (Hz)	The end frequency of Over Frequency derating	60	61.40	72	60	62	72	60	61.4	72
OvrFrqSlop (P/s)	The rate of Overfrequency derating	0.01	0.16	100	0.01	30	100	0.01	0.16	100
RecoveryFrq (Hz)	The recovery frequency of OverFrequency derating	58.80	60	66	58.8	59.90	66	58.8	60.00	66

OvrFrqRecoveryT(s)	The recovery time of OverFrequency derating	0	60	1200	0	20	1200	0	90	1200
OvrFrqDeratingMode	Over frequency derating enable/disable 0: Disable 1: Enable	0	0	1	0	0	1	0	0	1
CtrlMode	The control mode of active power 0: Disable dispatch 1: Remote dispatch 2: Local control	0	0	2	0	0	2	0	0	2
Percentage	Local electric dispatch Active Power setting value	0	100	100	0	100	100	0	100	100

Table 6-14 Power Derating Setup

Only for CPS SCA25KTL-DO-US-208

Grid Over Frequency Derating		Setting Range					
Parameter Name LCD Display	Description	IEEE1547			Rule21		
		Min	Default	Max	Min	Default	Max
VwcurveV1(%)	Grid overvoltage derating starting voltage V1	105.00	106.00	109.00	105.00	106.00	109.00
VwcurveP1(%)	Grid overvoltage derating starting power P1	0.0	100.0	100.0	0.0	100.0	100.0
VwcurveV2(%)	Grid overvoltage derating end voltage V2	106.00	110.00	110.00	106.00	110.00	110.00
VwcurveP2(%)	Grid overvoltage derating end power P2	0.0	0.0	100.0	0.0	0.0	100.0

OpenloopRespT(s)	Open loop response time	0.5	10.0	90.0	0.5	10.0	90.0
OvrFrqMin (Hz)	The trigger frequency of Over Frequency derating	60.00	60.50	72.00	60.00	60.50	72.00
OvrFrqMax (Hz)	The end frequency of Over Frequency derating	60.00	61.40	72.00	60.00	61.40	72.00
OvrFrqSlop (P/s)	The rate of Overfrequency derating	0.01	0.16	100.00	0.01	0.16	100.00
RecoveryFrq (Hz)	The recovery frequency of OverFrequency derating	58.80	60.00	66.00	58.80	60.00	66.00
OvrFrqRecoveryT (s)	The recovery time of OverFrequency derating	0	60	1200	0	60	1200
OvrFrqDeratingMode	Over frequency derating enable/disable 0: Disable 1: Enable	0	0	1	0	0	1
CtrlMode	The control mode of active power 0: Disable dispatch 1: Remote dispatch 2: Local control	0	0	2	0	0	2
Percentage(%)	Local electric dispatch Active Power setting value	0.0	100.0	100.0	0	100.0	100.0

6.2.6 Reactive Power Derating Setup

The Reactive Power Derating menu is used to set the Grid reactive power derating parameters including PF parameters, Qu parameters, etc. The parameters as shown in Table 6-.

<ul style="list-style-type: none"> Setting System Parameters Control Command Protection Parameters LVRT/HVRT Setup Power Derating Setup Reactive Power Derating Setup ARC Parameters 	<table border="1"> <thead> <tr> <th colspan="2">PF vs Grid Voltage</th> </tr> </thead> <tbody> <tr> <td>PFCurveP1</td> <td>50.0%</td> </tr> <tr> <td>PFpCurvePF1</td> <td>1.000</td> </tr> <tr> <td>PFCurveP2</td> <td>100.0%</td> </tr> <tr> <td>PFpCurvePF2</td> <td>-0.900</td> </tr> <tr> <td>PFCurveTriVolt</td> <td>100.00%</td> </tr> <tr> <td>PFCurveUndoVolt</td> <td>90.00%</td> </tr> <tr> <td></td> <td></td> </tr> <tr> <td></td> <td>P1/4</td> </tr> </tbody> </table>	PF vs Grid Voltage		PFCurveP1	50.0%	PFpCurvePF1	1.000	PFCurveP2	100.0%	PFpCurvePF2	-0.900	PFCurveTriVolt	100.00%	PFCurveUndoVolt	90.00%				P1/4	<table border="1"> <thead> <tr> <th colspan="2">Reactive Power vs Grid Voltage</th> </tr> </thead> <tbody> <tr> <td>QuCurveU1</td> <td>107.99%</td> </tr> <tr> <td>QuCurveQ1</td> <td>0.0%</td> </tr> <tr> <td>QuCurveU2</td> <td>110.00%</td> </tr> <tr> <td>QuCurveQ2</td> <td>-50.0%</td> </tr> <tr> <td>QuCurveU1i</td> <td>92.01%</td> </tr> <tr> <td>QuCurveQ1i</td> <td>0.0%</td> </tr> <tr> <td>QuCurveU2i</td> <td>90.00%</td> </tr> <tr> <td></td> <td></td> </tr> <tr> <td></td> <td>P2/4</td> </tr> </tbody> </table>	Reactive Power vs Grid Voltage		QuCurveU1	107.99%	QuCurveQ1	0.0%	QuCurveU2	110.00%	QuCurveQ2	-50.0%	QuCurveU1i	92.01%	QuCurveQ1i	0.0%	QuCurveU2i	90.00%				P2/4
	PF vs Grid Voltage																																							
	PFCurveP1	50.0%																																						
	PFpCurvePF1	1.000																																						
	PFCurveP2	100.0%																																						
	PFpCurvePF2	-0.900																																						
	PFCurveTriVolt	100.00%																																						
	PFCurveUndoVolt	90.00%																																						
		P1/4																																						
	Reactive Power vs Grid Voltage																																							
	QuCurveU1	107.99%																																						
	QuCurveQ1	0.0%																																						
	QuCurveU2	110.00%																																						
	QuCurveQ2	-50.0%																																						
QuCurveU1i	92.01%																																							
QuCurveQ1i	0.0%																																							
QuCurveU2i	90.00%																																							
	P2/4																																							
	<table border="1"> <thead> <tr> <th colspan="2">Reactive Power vs Grid Voltage</th> </tr> </thead> <tbody> <tr> <td>QuCurveQ2i</td> <td>50.0%</td> </tr> <tr> <td>QuCurveTriPower</td> <td>20.0%</td> </tr> <tr> <td>QuCurveUndoPower</td> <td>5.0%</td> </tr> <tr> <td></td> <td></td> </tr> <tr> <td></td> <td></td> </tr> <tr> <td></td> <td></td> </tr> <tr> <td></td> <td></td> </tr> <tr> <td></td> <td>P3/4</td> </tr> </tbody> </table>	Reactive Power vs Grid Voltage		QuCurveQ2i	50.0%	QuCurveTriPower	20.0%	QuCurveUndoPower	5.0%										P3/4	<table border="1"> <thead> <tr> <th colspan="2">Grid Reactive Power Derating</th> </tr> </thead> <tbody> <tr> <td>CtrlMode</td> <td>0</td> </tr> <tr> <td>Percentage</td> <td>0.0%</td> </tr> <tr> <td>PFSetValue</td> <td>1.000</td> </tr> <tr> <td>Reserve</td> <td></td> </tr> <tr> <td></td> <td></td> </tr> <tr> <td></td> <td></td> </tr> <tr> <td></td> <td></td> </tr> <tr> <td></td> <td></td> </tr> <tr> <td></td> <td>P4/4</td> </tr> </tbody> </table>	Grid Reactive Power Derating		CtrlMode	0	Percentage	0.0%	PFSetValue	1.000	Reserve											P4/4
Reactive Power vs Grid Voltage																																								
QuCurveQ2i	50.0%																																							
QuCurveTriPower	20.0%																																							
QuCurveUndoPower	5.0%																																							
	P3/4																																							
Grid Reactive Power Derating																																								
CtrlMode	0																																							
Percentage	0.0%																																							
PFSetValue	1.000																																							
Reserve																																								
	P4/4																																							

Only for CPS SCA25KTL-DO-US-208

<ul style="list-style-type: none"> Setting System Parameters Control Command Protection Parameters LVRT/HVRT Setup Power Derating Setup Reactive Power Derating Setup ARC Parameters 	<table border="1"> <thead> <tr> <th colspan="2">PF vs Grid Voltage</th> </tr> </thead> <tbody> <tr> <td>PFCurveP1</td> <td>50.0%</td> </tr> <tr> <td>PFpCurvePF1</td> <td>1.000</td> </tr> <tr> <td>PFCurveP2</td> <td>100.0%</td> </tr> <tr> <td>PFpCurvePF2</td> <td>-0.900</td> </tr> <tr> <td>PFCurveTriVolt</td> <td>100.00%</td> </tr> <tr> <td>PFCurveUndoVolt</td> <td>90.00%</td> </tr> <tr> <td></td> <td></td> </tr> <tr> <td></td> <td>P1/4</td> </tr> </tbody> </table>	PF vs Grid Voltage		PFCurveP1	50.0%	PFpCurvePF1	1.000	PFCurveP2	100.0%	PFpCurvePF2	-0.900	PFCurveTriVolt	100.00%	PFCurveUndoVolt	90.00%				P1/4	<table border="1"> <thead> <tr> <th colspan="2">Reactive Power vs Grid Voltage</th> </tr> </thead> <tbody> <tr> <td>QuCurveU1</td> <td>107.99%</td> </tr> <tr> <td>QuCurveQ1</td> <td>0.0%</td> </tr> <tr> <td>QuCurveU2</td> <td>110.00%</td> </tr> <tr> <td>QuCurveQ2</td> <td>-50.0%</td> </tr> <tr> <td>QuCurveU1i</td> <td>92.01%</td> </tr> <tr> <td>QuCurveQ1i</td> <td>0.0%</td> </tr> <tr> <td>QuCurveU2i</td> <td>90.00%</td> </tr> <tr> <td></td> <td></td> </tr> <tr> <td></td> <td>P2/4</td> </tr> </tbody> </table>	Reactive Power vs Grid Voltage		QuCurveU1	107.99%	QuCurveQ1	0.0%	QuCurveU2	110.00%	QuCurveQ2	-50.0%	QuCurveU1i	92.01%	QuCurveQ1i	0.0%	QuCurveU2i	90.00%				P2/4
	PF vs Grid Voltage																																							
	PFCurveP1	50.0%																																						
	PFpCurvePF1	1.000																																						
	PFCurveP2	100.0%																																						
	PFpCurvePF2	-0.900																																						
	PFCurveTriVolt	100.00%																																						
	PFCurveUndoVolt	90.00%																																						
		P1/4																																						
	Reactive Power vs Grid Voltage																																							
	QuCurveU1	107.99%																																						
	QuCurveQ1	0.0%																																						
	QuCurveU2	110.00%																																						
	QuCurveQ2	-50.0%																																						
QuCurveU1i	92.01%																																							
QuCurveQ1i	0.0%																																							
QuCurveU2i	90.00%																																							
	P2/4																																							
	<table border="1"> <thead> <tr> <th colspan="2">Reactive Power vs Grid Voltage</th> </tr> </thead> <tbody> <tr> <td>QuCurveQ2i</td> <td>50.0%</td> </tr> <tr> <td>QuCurveTriPower</td> <td>20.0%</td> </tr> <tr> <td>QuCurveUndoPower</td> <td>5.0%</td> </tr> <tr> <td></td> <td></td> </tr> <tr> <td></td> <td></td> </tr> <tr> <td></td> <td></td> </tr> <tr> <td></td> <td></td> </tr> <tr> <td></td> <td>P3/4</td> </tr> </tbody> </table>	Reactive Power vs Grid Voltage		QuCurveQ2i	50.0%	QuCurveTriPower	20.0%	QuCurveUndoPower	5.0%										P3/4	<table border="1"> <thead> <tr> <th colspan="2">Grid Reactive Power Derating</th> </tr> </thead> <tbody> <tr> <td>CtrlMode</td> <td>0</td> </tr> <tr> <td>Percentage</td> <td>0.0%</td> </tr> <tr> <td>PFSetValue</td> <td>1.000</td> </tr> <tr> <td>ReactivePowerOver</td> <td>Disable</td> </tr> <tr> <td></td> <td></td> </tr> <tr> <td></td> <td></td> </tr> <tr> <td></td> <td></td> </tr> <tr> <td></td> <td>P4/4</td> </tr> </tbody> </table>	Grid Reactive Power Derating		CtrlMode	0	Percentage	0.0%	PFSetValue	1.000	ReactivePowerOver	Disable								P4/4		
Reactive Power vs Grid Voltage																																								
QuCurveQ2i	50.0%																																							
QuCurveTriPower	20.0%																																							
QuCurveUndoPower	5.0%																																							
	P3/4																																							
Grid Reactive Power Derating																																								
CtrlMode	0																																							
Percentage	0.0%																																							
PFSetValue	1.000																																							
ReactivePowerOver	Disable																																							
	P4/4																																							

Only for CPS SCA50/60KTL-DO/US-480

Figure 6-14 Reactive Derating Setting

Table 6-15 Reactive Power Control (IEEE-1547/ Rule21 and ISO-NE)

Only for CPS SCA50/60KTL-DO/US-480

Grid Reactive Power Derating		Setting Range								
Parameter Name	Description	IEEE1547			Rule21			ISO-NE		
		Min	Default	Max	Min	Default	Max	Min	Default	Max
PFCurveP1(%)	Power of PF(P) Curve point 1	0	50	110	0	50	110	0	50	110
PFpCurvePF1	PF of PF(P) Curve point 1	-1.0, -0.8	1.0	0.8, 1.0	-1.0, -0.8	1.0	0.8, 1.0	-1.0, -0.8	1.0	0.8, 1.0
PFCurveP2(%)	Power of PF(P) Curve point 2	0	100	110	0	100	110	0	100	110
PFpCurvePF2	PF of PF(P) Curve point 2	-1.0, -0.8	-0.9	0.8, 1.0	-1.0, -0.8	-0.9	0.8, 1.0	-1.0, -0.8	-0.9	0.8, 1.0
PFCurveTriVolt (V)	The trigger voltage of PF(P)Curve	100	100	110	100	100	110	100	100	110
PFCurveUndoV olt (V)	PF curve revocation voltage	90	90	100	90	90	100	90	90	100

Table 6-16 Reactive Power Control (IEEE-1547 and Rule21)

Only for CPS SCA25KTL-DO-US-208

Grid Reactive Power Derating		Setting Range					
Parameter Name	Description	IEEE1547			Rule21		
		Min	Default	Max	Min	Default	Max
PFCurveP1(%)	Power of PF(P) Curve point 1	0.0	50.0	110.0	0.0	50.0	110.0
PFpCurvePF1	PF of PF(P) Curve point 1	-1.0, -0.8	1.000	0.8, 1.0	-1.0, -0.8	1.000	0.8, 1.0
PFCurveP2(%)	Power of PF(P) Curve point 2	0.0	100.0	110.0	0.0	100.0	110.0

PFpCurvePF2	PF of PF(P) Curve point 2	-1.0, -0.8	-0.900	0.8, 1.0	-1.0, -0.8	-0.900	0.8, 1.0
PFCurveTriVolt (%)	The trigger voltage of PF(P)Curve	100.00	100.00	110.00	100.00	100.00	110.00
PFCurveUndoV olt (%)	PF curve revocation voltage	90.00	90.00	100.00	90.00	90.00	100.00

Note: The PF and Q value can be adjusted by remote software if the “Remote” setting is selected.

1. **PFSetValue:** Set the PF value. This function changes the reactive power by adjusting the Power Factor.
2. **PFpCurve functions:** PFp curve mode. Using the curves to set the PFp setpoints (See Figure 6-15). These functions are only available for IEEE-1547 and Rule21 grid standards.

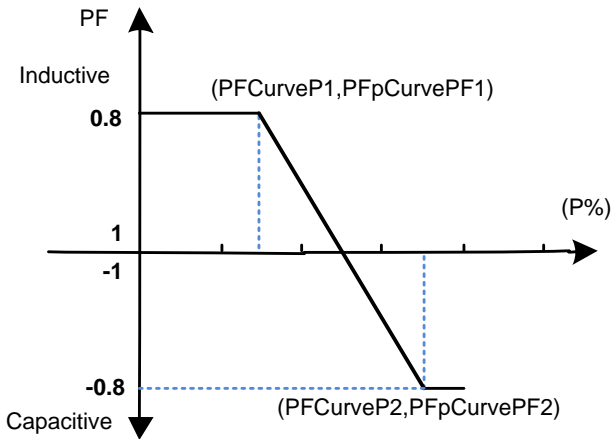

Figure 6-15 PF(P) Curve Mode



INSTRUCTION:

The PF (P) Curve function is only available for IEEE-1547 and Rule21 grid standards.

- 3. Q(U) Curve:** Q(U) curve mode. Using the curves to set the reactive power setpoints (See Figure 6-16). The reactive power compensation changes according to the grid voltage. These functions are only available for IEEE-1547 and Rule21 grid standards.

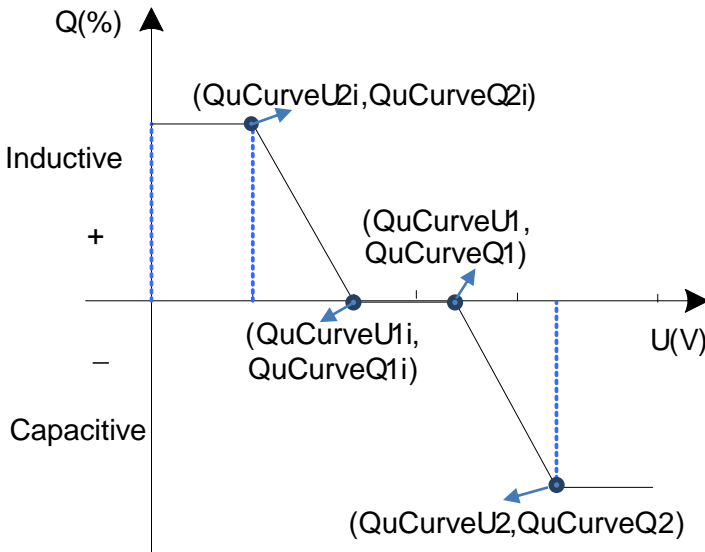

Figure 6-16 Q(U) Curve Mode



INSTRUCTION:

The Q(U) curve function is available for IEEE-1547 and Rule21 grid standards.

Table 6- lists the parameters for PF Set and Q(U) Curve modes. Press **ENT** to start the modes after the parameters are set.

Table 6-17 Reactive Power Control (IEEE-1547 / Rule21 and ISO-NE)

Only for CPS SCA50/60KTL-DO/US-480

Grid Reactive Power Derating		Setting Range								
Parameter name	Description	IEEE1547			Rule21			ISO-NE		
		Min	Default	Max	Min	Default	Max	Min	Default	Max
QuCurveU1 (V)	Voltage of Q(U) Curve point 1	100	107.9	110	100	103.3	110	100	107.99	110
QuCurveQ1 (%)	Reactive power of Q(U) Curve point 1	-66	0	66	-66	0	66	-66	0	66
QuCurveU2 (V)	Voltage of Q(U) Curve point 2	100	110	110	100	107	110	100	110	110
QuCurveQ2 (%)	Reactive power of Q(U) Curve point 2	-66	-50	55	-66	-30	66	-66	-50	66
QuCurveU1i (V)	Voltage of Q(U) Curve point 1i	90	92.01	100	90	96.7	100	90	92.01	100
QuCurveQ1i (%)	Reactive power of Q(U) Curve point 1i	-66	0	66	-66	0	66	-66	0	66
QuCurveU2i (V)	Voltage of Q(U) Curve point 2i	80	90	92	80	92	92	80	90	92
QuCurveQ2i (%)	Reactive power of Q(U) Curve point 2i	-66	50	66	-66	30	66	-66	50	66
QuCurveTriPower (V)	The trigger of Q(U) Curve	5	20	100	5	20	100	5	20	100
QuCurveEndPower (V)	The end of Q(U) Curve	5	5	100	5	5	100	5	5	100
CtrlMode	The control mode of reactive power 0: Disable dispatch mode. 1: Remote dispatch mode. 2: Local control, by Q 3: Local control, by PF 4: PF(P) curve 5: Q(U) curve	0	0	5	0	5	5	0	0	5
Percentage	Local Power Factor Setting	-66	0	66	-66	0	66	-66	0	66

PFSsetValue	Local Power Factor Setting	-1.0, -0.8	1.0	0.8, 1.0	-1.0, -0.8	0.950	0.8, 1.0	-1.0, -0.8	1	0.8, 1.0
-------------	----------------------------	---------------	------------	-------------	---------------	--------------	-------------	---------------	----------	-------------

Table 6-18 Reactive Power Control (IEEE-1547 and Rule21)

Only for CPS SCA25KTL-DO-US-208

Grid Reactive Power Derating		Setting Range					
Parameter name	Description	IEEE1547			Rule21		
		Min	Default	Max	Min	Default	Max
QuCurveU1 (%)	Voltage of Q(U) Curve point 1	100.00	107.99	110.00	100.00	107.99	110.00
QuCurveQ1 (%)	Reactive power of Q(U) Curve point 1	-66.0	0.0	66.0	-66.0	0.0	66.0
QuCurveU2 (%)	Voltage of Q(U) Curve point 2	101.00	110.00	120.00	101.00	110.00	120.00
QuCurveQ2 (%)	Reactive power of Q(U) Curve point 2	-66.0	-50.0	66.0	-66.0	-50.0	66.0
QuCurveU1i (%)	Voltage of Q(U) Curve point 1i	90.00	92.01	100.00	90.00	92.01	100.00
QuCurveQ1i (%)	Reactive power of Q(U) Curve point 1i	-66.0	0.0	66.0	-66.0	0.0	66.0
QuCurveU2i (%)	Voltage of Q(U) Curve point 2i	80.00	90.00	100.00	80.00	90.00	100.00
QuCurveQ2i (%)	Reactive power of Q(U) Curve point 2i	-66.0	50.0	66.0	-66.0	50.0	66.0
QuCurveTriPower (%)	The trigger of Q(U) Curve	5.0	20.0	100.0	5.0	20.0	100.0
QuCurveUndoPower (%)	The end of Q(U) Curve	5	5.0	100.0	5	5.0	100.0
CtrlMode	The control mode of reactive power 0: Disable dispatch mode. 1: Remote dispatch mode. 2: Local control, by Q 3: Local control, by PF	0	0	5	0	5	5

	4: PF(P) curve 5: Q(U) curve						
Percentage(%)	Local Power Factor Setting	-66.0	0.0	66.0	-66.0	0.0	66.0
PFSetValue	Local Power Factor Setting	-1.0, -0.8	1.000	0.8, 1.0	-1.0, -0.8	1.000	0.8, 1.0

6.2.7 Arc Parameters

ARC Parameters is used to enable/disable the ARC function and set the ARC parameters. These settings are only to be changed by CPS personnel with approval from the AHJ.

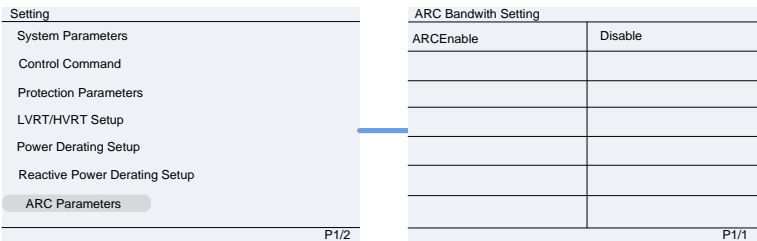

Figure 6-17 Arc Parameters Setting

6.2.8 Other Parameters

Other Parameters is used to set additional parameters including MPPT scan period, scan period, nominal derating step and GFCI, DCI parameters. Press ENT and use UP/DOWN keys to set parameters and enable/disable the functions. Press

functions. Press ENT to confirm the setting. The parameters shown in

Setting
Others Parameters

P1/2

Others		
PowerOnDelay(s)	5	
ReactivePowerstep	25.00%	
ErrSoftStartP	0.16%	
NormSoftStopP	6.00%	Enable
NormSoftStartP	4.00%	
NormalDeratingStep	6.00%	

Others		
PVSlowStartStep	10.00%	Disable
PVSlowStartPwDeita	5.00%	
FaultPowerT(C)	95.0	
FaultEnvT(C)	83.0	

Others		
GFCIStaticValue(mA)	650	Enable
GFCIStaticT(s)	0.2	
GFCIDynProFactor	100.0%	Enable
DCIProtection1	2.50%	Enable
DCIProtectionT1(s)	10.00	
DCIProtection2(mA)	950	Disable
DCIProtectionT2(s)	1.00	

Others		
PVStarupVolt(V)	330	
MPPTScanPeriod(s)	3600	Enable
ISOProtection(ohm)	140K	Enable
StartUPMinTemp(C)	-30.0	
DuplicationGroup	30%	
CtrParaGroup	4	

Setting
Others Parameters

P2/2

Others		
Island Protect	Enable	
Fan Detect	Enable	
Pid box	Disable	
OperationOverVol	120.00%	Enable
VirtualDamping	0	

Others	
MPPT1_OptVo1LowLim	200.0
MPPT1_OptVo1UpLim	1000.0
MPPT2_OptVo1LowLim	200.0
MPPT2_OptVo1UpLim	1000.0
MPPT3_OptVo1LowLim	200.0
MPPT3_OptVo1UpLim	1000.0

Only for CPS SCA50/60KTL-DO/US-480

Setting
Others Parameters

P1/2

Others		
PowerOnDelay(s)	5	
ReactivePowerstep	25.00%	
ErrSoftStartP	0.16%	
NormSoftStopP	6.00%	Enable
NormSoftStartP	4.00%	
NormalDeratingStep	6.00%	

P1/7

Others		
GFCIStaticValue(mA)	650	
GFCIStaticT(s)	0.2	Enable
GFCIDynProFactor	100.0%	Enable
DCIProtection1	2.50%	Enable
DCIProtectionT1(s)	10.00	
DCIProtection2(mA)	950	Disable
DCIProtectionT2(s)	1.00	

P3/7

Others		
PVSlowStartStep	10.00%	Disable
PVSlowStartPwDeita	5.00%	
FaultPowerT(C)	95.0	
FaultEnvT(C)	83.0	

P2/7

Others		
PVStartupVolt(V)	330	
MPPTScanPeriod(s)	3600	Enable
ISOProtection(ohm)	100K	Enable
StartUPMinTemp(C)	-30.0	
DuplicationControl	0%	
CtrParaGroup	4	
PID Check Settings	0	

P4/7

Setting
Others Parameters

P2/2

Others		
Island Protect	Enable	
Fan Detect	Enable	
Pid box	Disable	
OperationOverVol	120.00%	Enable
VirtualDamping	0	

P5/7

Others		
Anti reflux(DSP)	5.0	Disable
Anti reflux(LCD)	0	

P7/7

Others		
MPPT1_OptVo1LowLim	200.0	
MPPT1_OptVo1UpLim	1000.0	
MPPT2_OptVo1LowLim	200.0	
MPPT2_OptVo1UpLim	1000.0	
MPPT3_OptVo1LowLim	200.0	
MPPT3_OptVo1UpLim	1000.0	

P6/7

Only for CPS SCA25KTL-DO-US-208

Figure 6-18 and Table 6-

Setting
Others Parameters

P1/2

Others		
PowerOnDelay(s)	5	
ReactivePowerstep	25.00%	
ErrSoftStartP	0.16%	
NormSoftStopP	6.00%	Enable
NormSoftStartP	4.00%	
NormalDeratingStep	6.00%	

P1/7

Others		
GFCIStaticValue(mA)	650	
GFCIStaticT(s)	0.2	Enable
GFCIDynProFactor	100.0%	Enable
DCIProtection1	2.50%	Enable
DCIProtectionT1(s)	10.00	
DCIProtection2(mA)	950	Disable
DCIProtectionT2(s)	1.00	

P3/7

Others		
PVSlowStartStep	10.00%	Disable
PVSlowStartPwDeita	5.00%	
FaultPowerT(C)	95.0	
FaultEnvT(C)	83.0	

P2/7

Others		
PVStarupVolt(V)	330	
MPPTScanPeriod(s)	3600	Enable
ISOProtection(ohm)	100K	Enable
StartUPMinTemp(C)	-30.0	
DuplicationControl	0%	
CtrParaGroup	4	
PID Check Settings	0	

P4/7

Setting
Others Parameters

P2/2

Others		
Island Protect	Enable	
Fan Detect	Enable	
Pid box	Disable	
OperationOverVol	120.00%	Enable
VirtualDamping	0	

P5/7

Others		
Anti reflux(DSP)	5.0	Disable
Anti reflux(LCD)	0	

P7/7

Others		
MPPT1_OptVo1LowLim	200.0	
MPPT1_OptVo1UpLim	1000.0	
MPPT2_OptVo1LowLim	200.0	
MPPT2_OptVo1UpLim	1000.0	
MPPT3_OptVo1LowLim	200.0	
MPPT3_OptVo1UpLim	1000.0	

P6/7

Only for CPS SCA25KTL-DO-US-208

Figure 6-18 Other Parameters Setting

Table 6-19 Other Parameters

Only for CPS SCA50/60KTL-DO/US-480

Other Parameters		Setting Range								
Parameter Name	Description	IEEE1547			Rule21			ISO-NE		
		Min	Default	Max	Min	Default	Max	Min	Default	Max
PowerOnDelay (s)	Startup delay time	0	5	1200	0	5	1200	0	5	1200
ReactivePower Step (%)	Reactive Step	0.0	25.0	100.0	0.0	25.0	100.0	0.0	25.0	100.0
ErrSoftStartP (%/P)	Power startup step after Grid Fault	0.01	0.16	10	0.01	2	10	0.01	0.16	10
NormSoftStopP (%/P)	Normal power step in soft stop	0.01	6	100	0.01	10	100	0.01	10	100
NormSoftStartP (%/P)	Normal power step in soft startup	0.01	4	100	0.01	100	100	0.01	2	100
NormalDerating Step	Power step in Derating	0.01	6	100	0.01	100	100	0.01	6	100
PVSlowStartStep (%)	PVSlowStartStep	0.01	10.00	100.00	0.01	10.00	100.00	0.01	10.00	100.00
PVSlowStartPw Delta (%)	The output power should be slow increased due to the change of PV illumination at the Rule21 standard.	5.00	5.00	10.00	5.00	5.00	10.00	5.00	5.00	10.00
FaultPowerT	The trigger temperature of module (C)	95	95	95	95	95	95	95	95	95
FaultEnvT	The trigger temperature of enviroment (C)	83	83	83	83	83	83	83	83	83
GFCIStaticValue (mA)	The static threshold value of Leakage current	100	650	1000	100	650	1000	100	250	1000

Other Parameters		Setting Range								
Parameter Name	Description	IEEE1547			Rule21			ISO-NE		
		Min	Default	Max	Min	Default	Max	Min	Default	Max
GFCIStaticT (s)	The static threshold time of Leakage current	0	0.20	655	0	0.20	655	0	0.20	655
GFCIDynProFactor	The dynamic trigger coefficient of Leakage current	0	100	200	0	100	200	0	100	200
DCIProtection1	Maximum DCI value1	0.01	2.50	5	0.01	2.50	5	0.01	0.50	5
DCIProtectionT1 (s)	Trip time 1 of DCI	0	10	120	0	10	120	0	60	120
DCIProtection2 (mA)	Maximum DCI value2	5	950	5000	5	950	5000	5	950	5000
DCIProtectionT2 (s)	Trip time 2 of DCI	0	1	120	0	1	120	0	1	120
PVStartVolt(V)	PV start-up voltage	300	330	400	300	330	400	300	330	400
MPPTScanPeriod (s)	MPPT Scan Cycle	300	3600	5400	300	3699	5400	300	3600	5400
ISOProtection (Ω)	Minimum insulation resistance	1k	100k	2000k	1k	100k	2000k	1k	100K	2000k
StarUPMinTemp (C)	The minimum startup temperature	-35	-30	-20	-35	-30	-20	-35	-30	-20
Duplication Group	Parameter of repetitive control	0	30	100	0	30	100	0	0	100
CtrParaGroup	The enabled control parameters group.	0	4	4	0	4	4	0	4	4
Island Protect	Island enable/disable	0	1	1	0	1	1	0	1	1

Other Parameters		Setting Range								
Parameter Name	Description	IEEE1547			Rule21			ISO-NE		
		Min	Default	Max	Min	Default	Max	Min	Default	Max
	ee control 0: Disable 1: Enable									
Fan Detect	Fan detection enable/disable control 0: Disable 1: Enable	0	1	1	0	1	1	0	1	1
OperationOverVol	Operating overvoltage protection value	100	120	135	100	120	135	100	120	135
VirtualDamping	The parameter of Virtual Damping	0	0	15.000	0	0	15.000	0	0	15.000
Mppt1_OptV oLowLim	OptiVoltMinMpp t1	200.0	200.0	1500.0	200.0	200.0	1500.0	200.0	200.0	1500.0
Mppt1_OptV oUpLim	OptiVoltMaxMpp t1	200.0	1000.0	1500.0	200.0	1000.0	1500.0	200.0	1000.0	1500.0
Mppt2_OptV oLowLim	OptiVoltMinMpp t2	200.0	200.0	1500.0	200.0	200.0	1500.0	200.0	200.0	1500.0
Mppt2_OptV oUpLim	OptiVoltMaxMpp t2	200.0	1000.0	1500.0	200.0	1000.0	1500.0	200.0	1000.0	1500.0
Mppt3_OptV oLowLim	OptiVoltMinMpp t3	200.0	200.0	1500.0	200.0	200.0	1500.0	200.0	200.0	1500.0

Other Parameters		Setting Range								
Parameter Name	Description	IEEE1547			Rule21			ISO-NE		
		Min	Default	Max	Min	Default	Max	Min	Default	Max
Mppt3_OptV olUpLim	OptiVoltMaxMp pt3	200.0	1000.0	1500.0	200.0	1000.0	1500.0	200.0	1000.0	1500.0

Table 6-20 Other Parameters

Only for CPS SCA25KTL-DO-US-208

Other Parameters		Setting Range					
Parameter Name	Description	IEEE1547			Rule21		
		Min	Default	Max	Min	Default	Max
PowerOnDelay (s)	Startup delay time	0	5	1200	0	5	1200
ReactivePower Step (%)	Reactive Step	0.01	25.00	100.00	0.01	25.00	100.00
ErrSoftStartP (%/P)	Power startup step after Grid Fault	0.01	0.16	100.00	0.01	0.16	100.00
NormSoftStopP (%/P)	Normal power step in soft stop	0.01	6.00	100.00	0.01	6.00	100.00
NormSoftStartP (%/P)	Normal power step in soft startup	0.01	4.00	100.00	0.01	4.00	100.00
NormalDerating Step	Power step in Derating	0.01	6.00	100.00	0.01	6.00	100.00
PVSlowStartStep (%)	PVSlowStartStep	0.01	10.00	100.00	0.01	10.00	100.00
PVSlowStartPw Delta (%)	The output power should be slow increased due to the change of PV illumination at the	0.01	5.00	10.00	0.01	5.00	10.00

Other Parameters		Setting Range					
Parameter Name	Description	IEEE1547			Rule21		
		Min	Default	Max	Min	Default	Max
	Rule21 standard.						
FaultPowerT (°C)	The trigger temperature of module (°C)	95.0	95.0	95.0	95.0	95.0	95.0
FaultEnvT (°C)	The trigger temperature of environment (°C)	83.0	83.0	83.0	83.0	83.0	83.0
GFCIStaticValue (mA)	The static threshold value of Leakage current	100	650	1000	100	650	1000
GFCIStaticT (s)	The static threshold time of Leakage current	0.00	0.20	655	0.00	0.20	655
GFCIDynProFactor (%)	The dynamic trigger coefficient of Leakage current	0.0	100.0	200.0	0.0	100.0	200.0
DCIProtection1 (%)	Maximum DCI value1	0.10	0.50	5.00	0.10	0.50	5.00
DCIProtectionT1 (s)	Trip time 1 of DCI	0.00	60.00	120.00	0.00	60.00	120.00
DCIProtection2 (mA)	Maximum DCI value2	5	950	5000	5	950	5000
DCIProtectionT2 (s)	Trip time 2 of DCI	0.00	1.00	120.00	0.00	1.00	120.00
PVStartVolt(V)	PV start-up voltage	300	330	400	300	330	400
MPPTScanPeriod (s)	MPPT Scan Cycle	300	3600	5400	300	3600	5400
ISOProtection (kΩ)	Minimum insulation resistance	1	100	2000	1	100	2000
StarUPMinTemp (°C)	The minimum startup	-35.0	-30.0	-20.0	-35.0	-30.0	-20.0

Other Parameters		Setting Range					
Parameter Name	Description	IEEE1547			Rule21		
		Min	Default	Max	Min	Default	Max
	temperature						
Duplication Group (%)	Parameter of repetitive control	0	0	100	0	0	100
CtrParaGroup	The enabled control parameters group.	0	4	4	0	4	4
PID Cheak Setting	PID Checking enable/disable control	0	0	1	0	0	1
Island Protect	Island enable/disable control 0: Disable 1: Enable	0	1	1	0	1	1
Fan Detect	Fan detection enable/disable control 0: Disable 1: Enable	0	1	1	0	1	1
Pid box	Pid-box enable or disable	0	0	1	0	0	1
OperationOverVol (%)	Operating overvoltage protection value	100.00	120.00	135.00	100.00	120.00	135.00
VirtualDamping(Ω)	The parameter of Virtual Damping	0.000	0.000	5.000	0.000	0.000	5.000
Mppt1_OptV	OptiVoltMinMp	200.0	200.0	1500.0	200.0	200.0	1500.0

Other Parameters		Setting Range					
Parameter Name	Description	IEEE1547			Rule21		
		Min	Default	Max	Min	Default	Max
oLowLim(V)	pt1						
Mppt1_OptV oUpLim(V)	OptiVoltMaxMp pt1	200.0	1000.0	1500.0	200.0	1000.0	1500.0
Mppt2_OptV oLowLim(V)	OptiVoltMinMp pt2	200.0	200.0	1500.0	200.0	200.0	1500.0
Mppt2_OptV oUpLim(V)	OptiVoltMaxMp pt2	200.0	1000.0	1500.0	200.0	1000.0	1500.0
Mppt3_OptV oLowLim(V)	OptiVoltMinMp pt3	200.0	200.0	1500.0	200.0	200.0	1500.0
Mppt3_OptV oUpLim(V)	OptiVoltMaxMp pt3	200.0	1000.0	1500.0	200.0	1000.0	1500.0

Note: Compatibility among the functions

1. LVRT available another function will be fail as below:

Anti-islanding, QU, PF(P), PF Setting, reactive power setting, active power setting, over frequency derating, GFCL, Grid over frequency protection, Grid unbalance protection, DCI protection.

2. Only one of these four functions can be valid at one time: QU, PF(P), PF Setting and reactive power setting.

6.3 Power ON/OFF

6.3.1 Manual Power ON/OFF

Restarting the inverter is required after regulation setting or manual (fault) shut-down. Press **ESC** or **ENT** to access the Main Menu. Scroll the cursor down to highlight **POWER ON/OFF** and press **ENT** to select. Move the cursor to “ON” and press **ENT** to start the inverter. The inverter will start up and operate normally if the start-up conditions are met. Otherwise, the inverter will go to stand-by mode.

Normally, it is not necessary to Turn OFF the inverter, but it can be shut down manually if regulation setting or maintenance is required. Move the cursor from the main operation interface to **POWER ON/OFF** and press **ENT**. Move the cursor to “OFF” and press **ENT**, and then the inverter will be shut down.

6.3.2 Automatic Turn ON/OFF

The inverter will start up automatically when the output voltage and power of PV arrays meet the set value, AC power grid is normal, and the ambient temperature is within allowable operating range.

The inverter will be shut down automatically when the output voltage and power of PV modules are lower than the set value, the AC power grid fails, or the ambient temperature exceeds the normal range.

6.4 History Record

Move the cursor to History Record in the main menu interface. Press **ENT** to check the history information. There are 3 submenus in the History Record menu: Current Error, Running Record and Fault Record. See Figure 6-19.

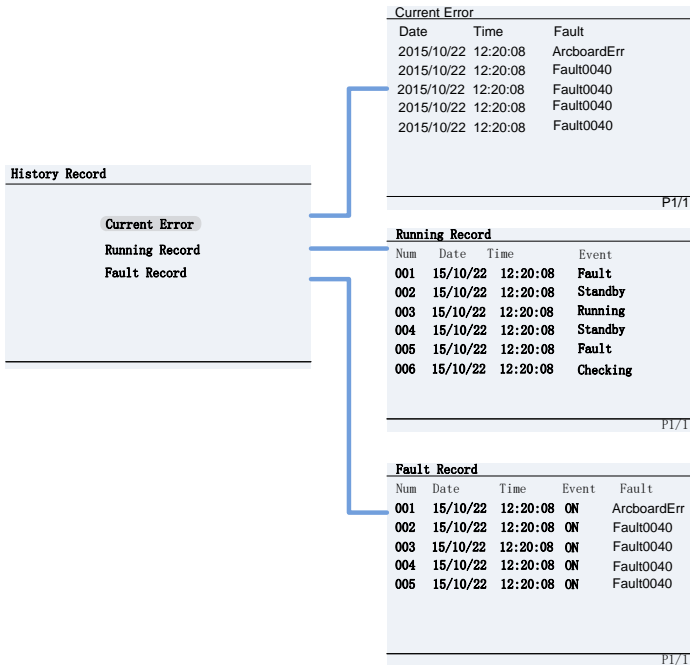

Figure 6-19 History Menu and Submenu

3. **Current Error:** This log will display any faults that are currently affecting the operation of the inverter.
4. **Running Record:** This log can store up to 128 running history messages. This includes normal operating events such as the inverter turning on, going into standby and turning off.
5. **Fault Record:** This log can store up to 128 fault codes.

6.5 Device Information

Press the **ESC** key to leave the main “operation interface” and press **ENT** to access the “Main Menu.” Using the arrow keys, scroll down to the submenu **Device Information** and press **ENT** to check the device information, as shown in Figure 6-20.

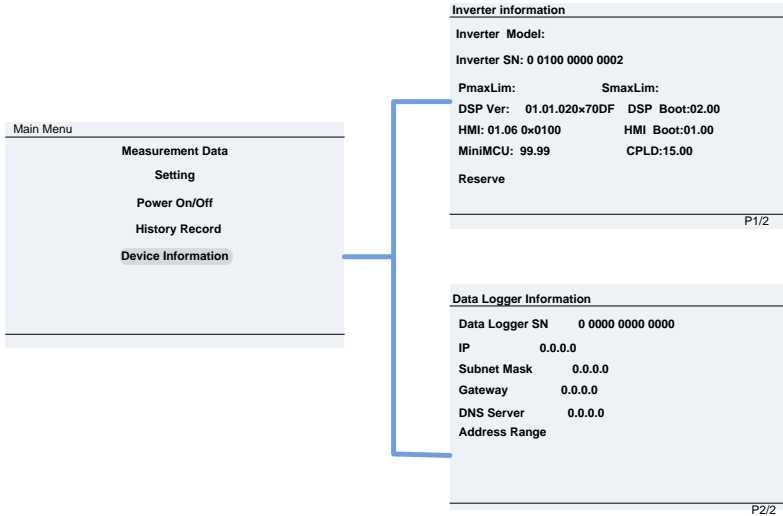

Figure 6-20 Device Information

This menu provides the information to identify the version of boards in the inverter, model number, serial number and data logger information. This information may be required when contacting CPS service.



WARNING:

Please follow the guidelines below before on-grid operation to eliminate possible dangers and to ensure safety.

6.6 Start-Up

Automatic start-up: The inverter will start up automatically when the output voltage and power of PV arrays meet the set value, AC power grid is normal, and the ambient temperature is within allowable operating range.

Manual Power ON/OFF: Manual Power ON/OFF is required after regulation setting or manual (fault) shut-down. Press **ESC** to and **ENT** to access the Main Menu, move the cursor to “ON/OFF” and press **ENT**. Once in the



“ON/OFF” submenu, move the cursor to “ON” and press **ENT** to start the inverter. Then the inverter will start up and operate normally if the start-up condition is met. Otherwise, the inverter will go to stand-by mode.

6.7 Shut-Down

Automatic shutdown: The inverter will be shut down automatically when the output voltage and power of PV modules are lower than the set value, AC power grid fails, or the ambient temperature exceeds the normal range.

Manual shutdown: Normally, it is not necessary to shutdown the inverter, but it can be shut down manually if regulation setting or maintenance is required.

Press **ESC** and then **ENT** to access the Main Menu. Move the cursor to the submenu **Manual Power ON/OFF** and press **ENT**. Move the cursor to “OFF” and press **ENT**, and then the inverter will be shut down.

6.8 Operation Mode

There are 4 operation modes: Logo/Start-up, Normal Operation, Standby and Fault modes. See section 4.3 for details of these modes.

1. **Logo/Start-up** mode displays the Chint Power Systems logo when the inverter is checking if conditions are met for connection after a manual start-up of the inverter.
2. **Normal Operation** mode is the default indication interface for normal operation. In this mode, the inverter is converting the DC power from the array to AC power, feeding it continuously to the grid.
3. **Standby** mode is active when the output voltage and power of PV modules do not meet the startup conditions or PV voltage and input power are lower than the set value. The inverter will check automatically whether it meets the startup conditions in this mode until it turns back to Normal Operation mode.

4. **Fault** mode is displayed when the inverter disconnects from the grid due to a fault in the inverter or grid. Check the Fault log under **Current Errors** and reference the “Troubleshooting” table in section 7 to determine the cause of the error.

6.9 Grid-tied Power Generation

The CPS SCA50KTL-DO/US-480 and SCA60KTL-DO/US-480 series inverters have an automatic grid-tied power generation process. It will check constantly whether AC power grid meets the conditions for grid-tied power generation, and test whether the PV array has adequate energy. After all conditions are met, the inverter will enter Normal Operation mode and export power to the grid. While generating power, the inverter can detect the power grid at all times, supply current, matching voltage and frequency of the grid and keep the photovoltaic array output at the maximum power point.

In case of any abnormality, the inverter will enter the protection program immediately. In low light conditions when power generation is not enough to keep the inverter in operation, the inverter will enter standby mode. When the voltage of PV array changes, becomes stable and higher than the required start value, the inverter will attempt to start grid-tied power generation again.

6.10 Firmware Upgrade

Update the firmware by using the USB flash:

1. Prepare a USB flash drive (Capacity less than 8G) and format the drive to FAT32.
 - a. Insert the USB flash drive into a computer.
 - b. When the USB drive appears in the File Explorer Right click the drive and select “Format...”. The File system should display “FAT32” as default. If not, make this selection and click “start.”

2. Copy the LCD firmware file and the DSP firmware file into the USB flash drive. The upgrade file needs to be placed in the root directory. Contact CPS service for the latest firmware files.
3. Insert the USB flash drive into USB port on the inverter's communications board.

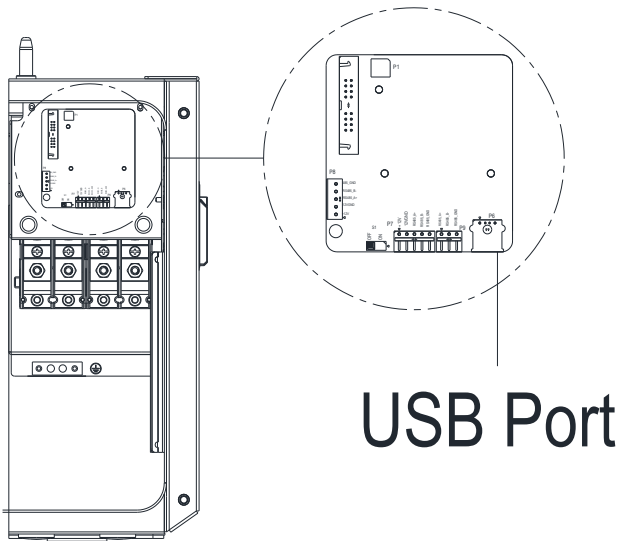

Figure 6-21 USB Port for Firmware Upgrades

4. Using the password to enter the **Setting** menu and select **Firmware Update**. Choose the firmware to be updated (LCD or DSP) and follow the prompts on the screen. See Figure 6-22.
5. When the update is successful repeat the process, if necessary, to update the next firmware (DSP or LCD). Should the update fail, return to step 4 when prompted and repeat the process.

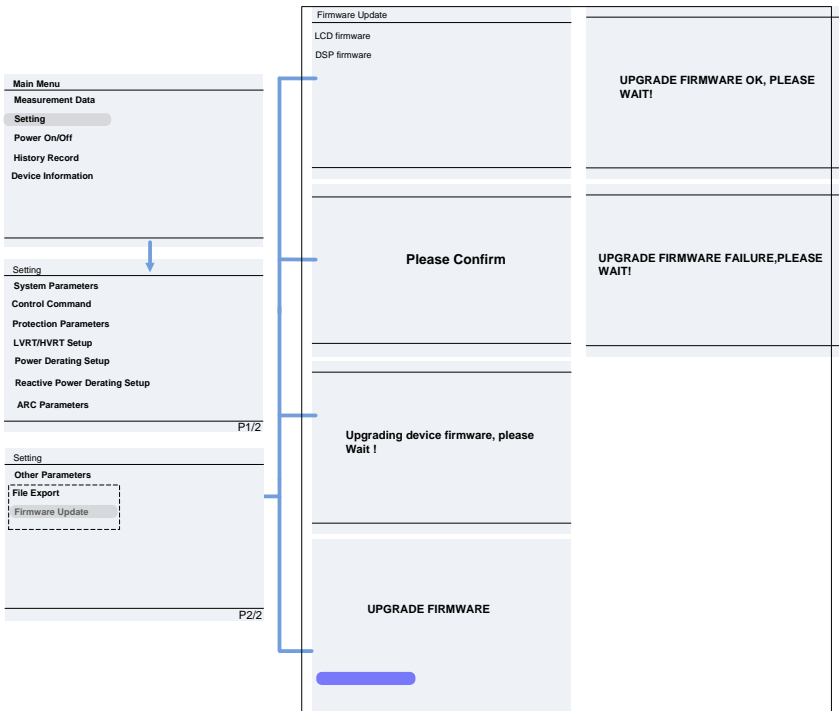

Figure 6-22 Firmware Upgrade Interface

Note: File Export and Firmware Update need super user rights

7 Fault Shutdown and Troubleshooting

If a fault occurs within the system, the inverter will recognize and report via the LED or LCD panel. If this occurs, reference the following section prior to contacting post-sales service. This will ensure the quickest time to resolution possible.

7.1 LED Fault and Troubleshooting

Please refer to the definition of LED lights in Table 4-1 and troubleshoot according to Table 7-1:

Table 7-1 Troubleshooting of LED Lights

LED fault status	Solutions
Neither the “Power” LED nor the LCD screen lights up.	<ol style="list-style-type: none"> 1. Turn off the external AC breaker 2. Switch the DC switch to “OFF” position 3. Check the PV input voltage and polarity
The “GRID” LED is blinking.	<ol style="list-style-type: none"> 1. Turn off the external AC breaker 2. Switch the DC switch to “OFF” position 3. Check whether the grid voltage is normal and whether the cable connection of AC side is correct and secure
The “RUN” LED lights off or “FAULT” LED lights up.	Refer to Table 7-2 through Table 7-4 for troubleshooting



DANGER:

Disconnect the inverter from AC grid and PV modules before opening the equipment. Make sure hazardous high voltage and energy inside the equipment has been discharged.

Do not operate or maintain the inverter until at least 5 minutes after

disconnecting all sources of DC and AC.

7.2 LCD Fault and Troubleshooting

The inverter will shut down automatically if the PV power generation system fails, such as output short circuit, grid overvoltage/undervoltage, grid overfrequency/underfrequency, high environmental temperature or internal malfunction of the machine. The fault information will be displayed on the LCD screen. Please refer to 6.4 History Record for detailed operation.

The causes of a fault can be identified based on the faults listed in Table 7-2 through

Table 7-2 LCD Troubleshooting WARNING

Type	Error/State	Fault Description / Instruction
Warning	Warn0030 (EepromErr)	Definition: Internal alarm
		Recommended solutions: 1. Observe for 5 minutes to see whether the alarm will be eliminated automatically 2. Contact post-sales service if not corrected
	Warn0050 (TempSensorErr)	Recommended solutions: 1. Observe temperature display 2. Switch off external AC disconnect, then back on to reboot the system 3. Contact post-sales service if not corrected

Table 7-7 to Table 7-7 there are 4 types of fault: alarm, protection, warning and hardware fault. Proper analysis is recommended before contacting post-sales service to ensure your quickest time to resolution.

Table 7-3 LCD Troubleshooting ALARM

Type	Error/State	Fault Description / Instruction
Alarm	TempSensorErr	Definition: Prompt detection of abnormal temperature
		Possible causes: 1. Temperature Sensor socket connector has poor contact 2. Temperature Sensor is damaged
		Recommended solutions: 1. Observe temperature display 2. Switch off external AC disconnect, then back on to reboot the system; 3. Contact post-sales service if not corrected
	CommErr	Definition: Communication inside inverter fails
		Possible causes: Terminal block connectors of internal communication wires have poor contact
		Recommended solutions: 1. Observe for 5 minutes to see whether the alarm will be eliminated automatically 2. Switch off external AC disconnect, then back on to reboot the system 3. Contact post-sales service if not corrected
	ExtFanErr	Definition: Cooling fan failure
		Possible causes: 1. Fan is blocked 2. Fan service life has expired 3. Fan socket connector has poor contact
		Recommended solutions: 1. Observe for 5 minutes to see whether the alarm will be eliminated automatically 2. Check for foreign objects on fan blades; 3. Switch off external AC disconnect, then back on to reboot the system 4. Contact post-sales service if not corrected
	EepromErr	Definition: Internal alarm
		Possible causes: Internal memory has a problem
		Recommended solutions: 1. Observe for 5 minutes to see whether the alarm will be eliminated automatically 2. Contact post-sales service if not corrected

Table 7-4 LCD Troubleshooting PROTECTION

Type	Error/State	Fault Description / Instruction
Protection	Protect0090 (Bus over voltage)	<ol style="list-style-type: none"> Restart inverter by turning both AC and DC switches off. Wait for 1 minute for all energy to discharge and turn both switches ON If inverter cannot clear fault, replace inverter
	Protect0070 (Bus imbalance)	<ol style="list-style-type: none"> Raise limit of IDCmax (for example, 400mA) to allow inverter more room to adjust in transient condition to cope with imbalance of impedance and voltage between Grid phases If after adjustment, alarm still occurs, replace inverter
	Protect0030 (Inverter Over Current)	<ol style="list-style-type: none"> Restart inverter by turning both AC and DC switches off. Wait for 1 minute for all energy to discharge and turn both switches ON If inverter cannot clear fault, replace inverter
	GridV.OutLim	<ol style="list-style-type: none"> Check the AC connections and AC voltage is within range Restart the inverter again
	GridF.OutLim	<ol style="list-style-type: none"> Check the AC connections and AC frequency is in range Check the measured frequency value on the LCD, if within limit, restart the inverter
	Protect0020 (Grid relay error)	<ol style="list-style-type: none"> Restart inverter by turning both AC and DC switches off. Wait for 1 minute for all energy to discharge and turn both switches ON If inverter cannot clear fault, replace inverter
Protection	TempOver (Over-temperature protection)	<ol style="list-style-type: none"> Confirm the external ambient temperature is within the specified range of operating temperature Check whether air inlet is blocked Check whether fan is blocked Check whether the location of installation is appropriate or not Observe for 30 minutes and see whether the alarm will be eliminated automatically Contact post-sales service if not corrected
	Protect0180 (The sampling offset of DCI)	<ol style="list-style-type: none"> If the inverter can start up, then recalibrate If the inverter consistently reports this alarm and can not start up, then replace inverter
	Protect0170 (DCI high)	<ol style="list-style-type: none"> Raise limit of DCImax (for example, 400mA) to allow inverter more room to adjust in transient condition to cope with imbalance of impedance and voltage between grid phases After raising the limit, if inverter cannot clear fault, replace inverter

Table 7-5 LCD Troubleshooting PROTECTION (cont.)

Type	Error/State	Fault Description / Instruction
Protection	IsolationErr (Insulation resistance low)	Check wires of PV and ground: 1. Turn OFF AC switch to disconnect from grid 2. Open fuse holders to isolate PV strings. Test strings with string test set. 3. Add one PV string at a time, and start up inverter to see if alarm occurs. 4. If no alarm, turn OFF AC switches to disconnect from grid and add the next string. Turn AC switch on and start up inverter again 5. Continue until you can find the string that triggers the alarm. Trace back the faulted string to find any leakage to Earth Ground 6. The parameter "ISOResist" in hidden menu can be adjusted
	GFCIErr (leakage current high)	Check wires of PV and ground: 1. Turn OFF AC switch to disconnect from grid. 2. Open fuse holders to isolate PV strings. Test strings with string test set 3. Add one PV string at a time and start up inverter to see if alarm occurs. 4. If no alarm, turn OFF AC switches to disconnect grid, add in the next string. Start inverter again 5. Continue until the string that triggers the alarm is identified. Trace back the faulted string to find any leakage to Earth Ground
	Protect0150 (Mini MCU Fault)	1. Restart inverter by turning both AC and DC switches OFF. Wait for 1 minute for all energy to discharge and turn both switches ON 2. If inverter cannot clear fault, replace inverter
	Protect0110 (BUS over voltage (firmware))	1. Restart inverter by turning both AC and DC switches OFF. Wait for 1 minute for all energy to discharge and turn both switches ON 2. If inverter cannot clear fault, replace inverter
Protection	Protect0100 (The sensor fault of leakage current)	1. Restart inverter by turning both AC and DC switches OFF. Wait for 1 minute for all energy to discharge and turn both switches ON 2. If inverter cannot clear fault, contact CPS Service to replace Filter board or inverter.
	PVxReverse (PVx input reverse connection x=1,2,3)	1. Turn DC Switch OFF 2. Open Fuse holders to isolate PV strings 3. Use meter to find out which PV string is connected in reverse polarity 4. Correct PV string connection
	PVx Over current (PVx Over current x=1,2,3)	1. Check PV input Current 2. Restart inverter by turning both AC and DC switches OFF. Wait for 1 minute for all energy to discharge and turn both switches ON 3. If inverter cannot clear fault, replace inverter
	PV2VoltOver (PVx Over Volt x=1,2,3)	1. Measure voltage at DC terminals in wiring box and compare with reading in "Measurement Data" menu. PV voltage must be less than 1000V in open circuit condition 2. If display reading is not within 2% of meter reading, replace inverter 3. If display reading is within 2% of meter reading, adjust number of panels in the string.

Table 7-6 LCD Troubleshooting PROTECTION (cont.)

Type	Error/State	Fault Description / Instruction
Protection	Protect0230 (Inverter open-loop self-test fault)	<ol style="list-style-type: none"> Restart inverter by turning both AC and DC switches OFF. Wait for 1 minute for all energy to discharge and turn both switches ON If inverter cannot clear fault, replace inverter
	ARC Protect	<ol style="list-style-type: none"> Check logic connector to Arc board is secure. Run Arc Fault Test from "Settings" Menu If Alarm re-occurs, contact CPS Service to replace arc board or wiring box
	Arcboard Err	<ol style="list-style-type: none"> Check logic connector to Arc board is secure. Run Arc Fault Test from "Settings" Menu If Alarm re-occurs, contact CPS Service to replace arc board or wiring box

Table 7-7 LCD Troubleshooting FAULT

Type	Error/State	Fault Description / Instruction
Fault	Fault0020 (Bus over volt Hardware)	<ol style="list-style-type: none"> Restart inverter by turning both AC and DC switches OFF. Wait for 1 minute for all energy to discharge and turn both switches ON If inverter cannot clear fault, replace inverter
	Fault0060 (CPLD Fault)	<ol style="list-style-type: none"> Restart inverter by turning both AC and DC switches OFF. Wait for 1 minute for all energy to discharge and turn both switches ON If inverter cannot clear fault, replace Control Board or inverter
	Fault0080 (Bus Hardware over current fault)	<ol style="list-style-type: none"> Restart inverter by turning both AC and DC switches OFF. Wait for 1 minute for all energy to discharge and turn both switches ON If inverter cannot clear fault, replace inverter
Fault	Fault0090 (Dynamic leakage current high)	<p>Check wires of PV and ground:</p> <ol style="list-style-type: none"> Turn OFF AC switch to disconnect inverter from grid Open fuse holders to isolate PV strings. Test strings with meter Add one PV string and start inverter to see if alarm occurs. If no alarm, turn OFF AC switches to disconnect from grid and add in the next string. Start inverter again. Continue until the string that triggers the alarm is identified. Trace back the faulted string to find any leakage to Earth Ground.
	Fault0100 (Grid relay fault)	<ol style="list-style-type: none"> Restart inverter by turning both AC and DC switches OFF. Wait for 1 minute for all energy to discharge and turn both switches ON If inverter cannot clear fault, replace inverter

	Fault0110 (Bus imbalance)	<ol style="list-style-type: none"> 1. Raise limit of IDCmax (for example, 400mA) to allow inverter more room to adjust in transient condition to cope with imbalance of impedance and voltage between grid phases 2. If after adjustment, alarm still occurs, replace inverter
	Fault0130 (Bus over total voltage)	<ol style="list-style-type: none"> 1. Restart inverter by turning both AC and DC switches OFF. Wait for 1 minute for all energy to discharge between OFF and turn both switches ON 2. If inverter cannot clear fault, replace inverter
	Fault0150 (Open-loop self-check failure)	<ol style="list-style-type: none"> 1. Restart inverter by turning both AC and DC switches OFF. Wait for 1 minute for all energy to discharge and turn both switches ON 2. If inverter cannot clear fault, replace inverter



WARNING:

All the installation and wiring connections should be performed by qualified technical personnel. Disconnect the inverter from PV modules and the AC supply before undertaking maintenance.

Do not operate or maintain the inverter until at least 5 minutes after disconnecting all sources of DC and AC.

8 Maintenance and De-installation

This section defines the activities required to properly maintain the inverter and must be facilitated by qualified personnel, trained in the installation, de-installation and maintenance of inverters.

8.1 Product Maintenance

Maintenance is required to ensure the inverter remains in proper condition, prolonging service life and prevent potential issues.

8.1.1 Check Electrical Connections

Check all conductor connections as regular maintenance inspection every 6 months to one year, depending on the temperature changes at the installation site.

- Check the conductor/cable connections. If loose, tighten all the terminals to proper torque, referring to 3.3 Electrical Installation.
- Check for damage to the conductor/cable jacket. Repair or replace any damaged conductors/cables.

8.1.2 Clean the Air Vent Grate

The inverter can become hot during normal operation. It uses built in cooling fans to provide sufficient air flow and help in heat dissipation.

Check the air vent grate regularly to make sure it is not blocked. Clean the grate with a soft brush or vacuum cleaner attachment if necessary. The frequency of this cleaning depends on the installation environment.

8.1.3 Replace the Cooling Fans

If the internal temperature of the inverter is too high or abnormal noise is heard, assuming the air vent is not blocked and is clean, it may be



necessary to replace the external fans. Please refer to Figure 7-1 for replacing the cooling fans.

1. Use a No. 2 Phillips head screwdriver to remove the 10 screws on the fan tray (6 screws on the upper fan tray, and 4 screws on the lower fan tray).
2. Disconnect the waterproof cable connector from the cooling fan.
3. Use a No. 2 Phillips head screwdriver to remove the screws. Each fan is attached to the fan tray with 4 screws.
4. Attached the new cooling fans on the fan tray and screw into place. Fasten the cable on the fan tray with cable ties.
5. Torque value: 0.8-1N.m (7.1-8.91in-lbs)
6. Install the assembled fan tray back on the inverter and secure with the original screws.
7. Torque value: 1.2N.m (10.6in-lbs)

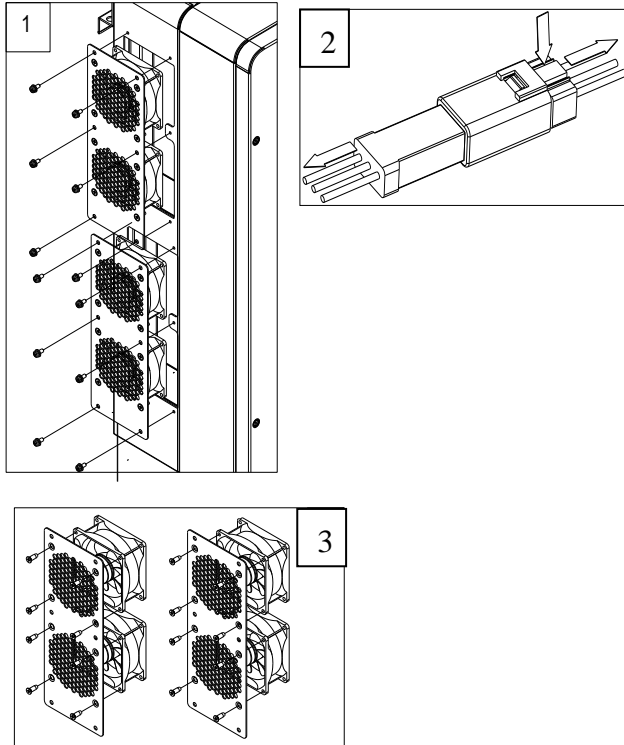

Figure 8-1 Replacing Cooling Fans



DANGER:

Please disconnect the electrical connection in strict accordance with the following steps. Otherwise, the inverter will be damaged and the service personnel's life will be endangered.

8.1.4 Replace the Inverter

Please confirm the following items before replacing the inverter:

- The AC breaker of inverter is turned off.
- The DC switch of the inverter is turned off.

Now replace the inverter according to the following steps:

1. Unlock the padlock if one is installed on the inverter.

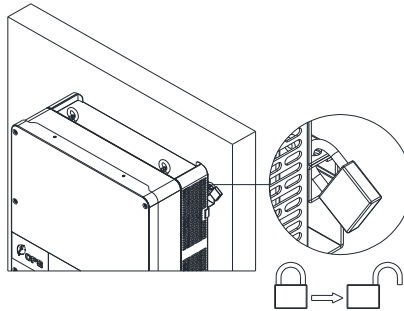

Figure 8-2 Unlock the padlock

2. Use a No. 3 Phillips head screwdriver to unscrew the 2 screws on both sides of the inverter.

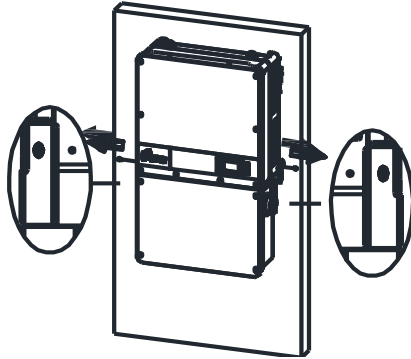

Figure 8-3 Remove the screws on both sides

3. Use a No. 10 Hex wrench to remove the 4 screws between the inverter and the wiring box. Lift the inverter enclosure and disconnect from the wiring box.

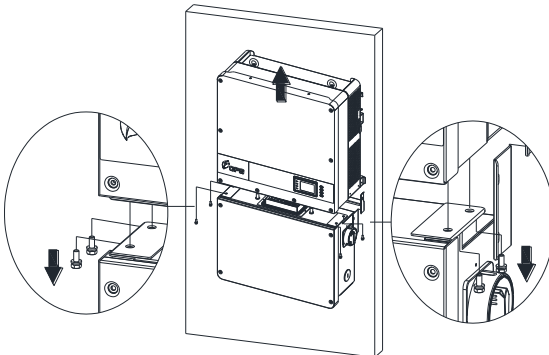

Figure 8-4 Disconnect the main housing from the wiring box

4. If the replacement inverter is onhand and to be installed immediately, skip this step and refer to section 3.2 for installation of the inverter.

Otherwise, use a No. 2 Phillips head screwdriver to remove the 2 screws on the left side of the wiring box, and remove the bulkhead cover. Attach the cover on the connector of wiring box. Torque value: 1.6N.m (14.2in-lbs)

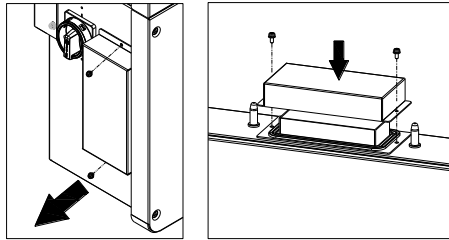

Figure 8-5 Install the cover on the connector of the wiring box

The cover connector does not provide a watertight seal – if inverter replacement is not immediately available, watertight integrity must be maintained by method in addition to connector cover.

8.2 De-installing the Inverter

De-install the inverter and wire box assembly according to the following steps when the inverter needs to be removed:

1. Turn off the external AC breaker and/or system disconnect switch using lock-out/tag-out procedures.
2. Turn off the external DC breaker and/or disconnect switch, if present, and use lock-out/tag-out procedures.
3. Switch the inverter's AC disconnect switch to "OFF" position.
4. Switch the inverter's DC disconnect switch to "OFF" position.
5. **Wait for 5 minutes to ensure the internal capacitors have been completely discharged.**
6. Measure the AC output conductor terminal voltage against the ground. The meter should now read 0V.

7. Disconnect the AC and PE cables referring to “3.3.4 AC and ground connection”.
8. Disconnect the DC cables referring to “3.3.3 DC connection”. **Caution:** if PV strings terminate directly in the wiring box and do not pass through a breaker or switch that was opened in Step 2 these strings may be energized.
9. De-install the inverter by reversing the installation steps found in section 3.2 Mechanical Installation.



9 Accessories

The CPS SCA25KTL-DO/US-208, CPS SCA50KTL-DO/US-480 and SCA60 KTL-DO/US-480 inverters have several optional accessories that allow the inverter to support a wide range of real-world applications.

9.1 Fuse Bypass Terminals

The Fuse Bypass Terminals allow for a reduction in the number of DC homeruns by combining the PV source circuits outside of the inverter wirebox and terminating with one pair of DC inputs to each of the three MPPTs. Note that external over current protection for the PV source circuits is required outside of the inverter. The MPPT positive inputs IN1+, IN2+, and IN3+ are isolated from one another by design, although the MPPT negative inputs IN1-, IN2-, and IN3- are combined via a common bus structure. The Fuse Bypass Terminals CPS SCA50KTL-DO/US-480 and SCA60 KTL-DO/US-480

9.1.1 Bypass Input Terminal Instructions

1. A maximum #2AWG wire should be used to minimize stress on the adapter.
2. Remove the wirebox cover (Figure 9-1).
3. Remove the plastic touch safe finger guards (Figure 9-2).
4. Use a No. 2 Phillips head screwdriver to install the Bypass Terminals on each bus by fastening each terminal with the M4 screws. Torque value of 14 in-lbs (1.6 N.m) (Figure 9-3 and Figure 9-4).
5. Use a No. 10 wrench to fasten the three pairs of DC input cables to each of the Bypass Terminals at IN1+, IN2+, IN3+ (Figure 9-3) and IN1-, IN2-, IN3- (Figure 9-4) with the M6 screws. Torque value of 50 in-lbs (6.0N.m.).
6. Reinstall the plastic touch safe finger guards. Torque value #
7. Reinstall the wirebox cover. Torque to 35.4 in-lbs (4N.m).



Figure 9-1 Remove Wirebox Cover

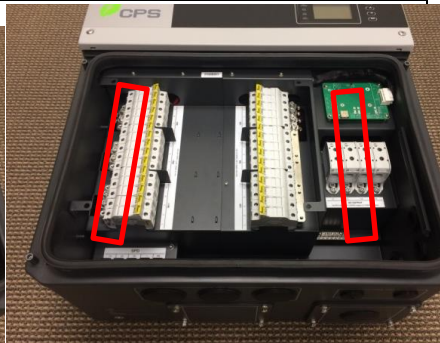

Figure 9-2 Remove Plastic Touchsafe Finger Guards

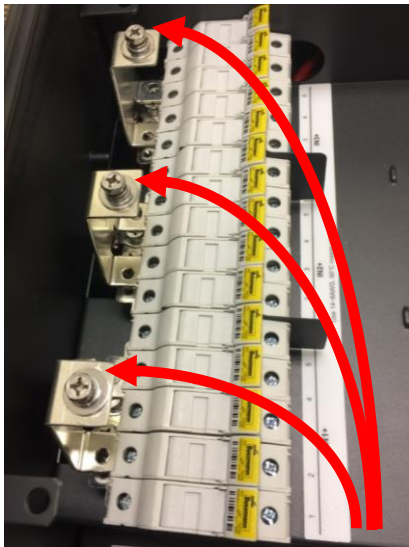

Figure 9-3 Bypass Terminals Installed on POS Input



Figure 9-4 Bypass Terminals Installed on NEG Bus

9.2 Shade Cover (SSC-60ST)

9.2.1 Protection from Harsh Conditions

Shade covers provide added protection for inverters against harsh environmental conditions like direct sunlight, snow, sleet, ice, hail, and reduce soiling from dust and birds. **When installing the inverter at tilts of 75° or less from horizontal the shade cover is required.** Protect your inverter for many years.

9.2.2 Increased Energy Production

Depending on the application and environment, shade covers will help to increase energy production by reducing potential power derating due to excessive ambient temperatures. Inverters derate in extreme temperatures to protect themselves from over temperature conditions.

Field testing at PVEL showed up to 15% reduction in operating temperatures of inverters with shade covers installed in direct sunlight. This report can be found on the CPS America website under application notes.

<https://www.chintpowersystems.com/downloads/application-notes/PVEL-Field-Testing-Report-28kW-Inverter-Shade-Plate.pdf>

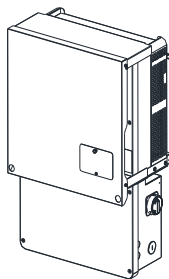

Figure 9-5 Shade Cover installed on CPS 25/50/60kW inverter

9.3 Y-Comb Terminal Block (Optional)

The Y-Comb is intended for use in the **SCA25KTL-DO/US-208** 、 SCA 50 /60KTL-DO/US-480 inverters. This accessory is applied between two adjacent fuseholders within the inverter wire-box and distributes current between the two fuseholders. When products such as Y-branch connectors are used in the array field to combine the output of two strings the current is as much as 30 or 40A. In order to distribute current and provide optimal thermal results the Y-Comb is required.

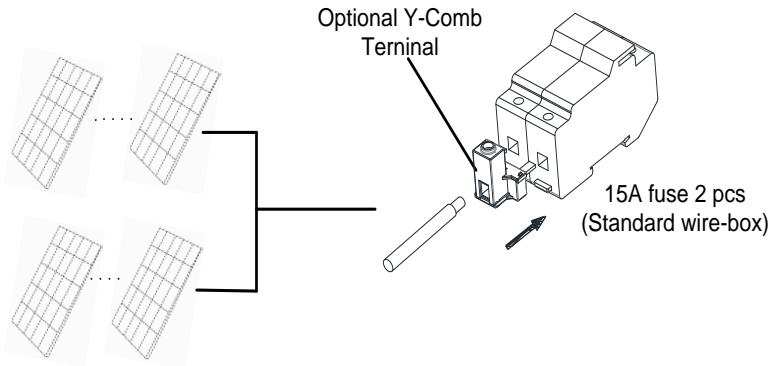

Figure 9-6 Y-Comb Terminal Block

10 Technical Data

10.1 Datasheet

Model Name	CPS SCA 25KTL-DO/US-208	CPS SCA 50KTL-DO/US-480	CPS SCA 60KTL-DO/US-480
DC Input			
Max. PV Power	37.5kW	75kW (30kW per MPPT)	90kW (33kW per MPPT)
Max. DC Input Voltage	1000V _{DC}		
Operating DC Input Voltage Range	200-950V _{DC}		
Start-up DC Input Voltage / Power	330V / 80W		
Number of MPP Trackers	3		
MPPT Voltage Range	480-850V _{DC}	480-850V _{DC}	540-850V _{DC}
Max.PV Short-Circuit Current (I _{sc} x 1.25)	135A (45A per MPPT)	204A (68A per MPPT)	
Number of DC Inputs	6 inputs, 2 per MPPT	15 inputs, 5 per MPPT	
DC Disconnection Type	Load rated DC switch		
DC Surge Protection	Type II MOV, 2800V _C , 20kA I _{TM} (8/20μS)		
AC Output			
Rated AC Output Power	25kW	50kW	60kW
Max. AC Apparent Power	25kVA	50kVA/55kVA	60kVA/66kVA
Rated Output Voltage	208V _{AC}	480V _{AC}	
Output Voltage Range	183-228 V _{AC}	422-528V _{AC}	
Grid Connection Type	3Φ/PE/N (Neutral optional)		
Max. AC Output Current ¹	69.5A@208V _{AC}	60.2A/66.2A@480V _{AC}	72.2A/79.4A@480V _{AC}
Max AC OCPD Rating	125A	110A	125A
Rated Output Frequency	60Hz		
Output Frequency Range ²	57-63Hz		
Power Factor	>0.99 (±0.8 adjustable)		



Dimensions (HxWxD)	39.4 x 23.6 x 10.24 in. (1000×600×260mm)
Weight	Inverter:123.5lbs/56kg; Wirebox:33lbs/15kg
Mounting / Installation Angle ⁴	15 to 90 degrees from horizontal (vertical, or angled)
AC Termination	M8 Stud Type Terminal Block (Wire range: #6-3/0AWG CU or #6-3/0AWG AL) Lugs not supplied
DC Termination	Screw Clamp, Neg. Busbar (RSD version) Wire range: #14 - #6AWG CU
Fused String Inputs (2/5 per MPPT)	15A standard fuse value (Fuse values up to 30A acceptable)
Safety	
PV Arc-Fault Circuit Protection	Type 1
Safety and EMC Standard	UL 1741, CSA C22.2 No. 107.1; UL 1699B; FCC Part 15
Grid Standard and SRD	IEEE 1547, IEEE 1547.1, UL 1741SA(Rule 21); HECO (Rule 14)
Smart-Grid Features	Voltage-RideThru, Frequency-RideThru, Soft-Start, Volt-Var, Frequency-Watt, Volt-Watt

3) See Chapter 3.1 for further requirements regarding non-operating conditions.

4) See Chapter 3.2 for Shade Cover accessory requirement for installation angles of 75 degrees or less.

10.2 Measurement Tolerances

The data supplied by the inverter may differ from measurements taken by certified measuring instruments (e.g. output meters, multimeters and grid analysers). The inverter is not a measuring instrument and has wider tolerances for the measurements it makes.

The inverter tolerances are generally:

- $\pm 5\%$ for real-time measurements with output power below 20% nominal power
- $\pm 3\%$ for real-time measurements with output power above 20% nominal power
- $\pm 4\%$ for all statistical data

CPS inverter tolerances are specified below:

- Voltage tolerances: $\pm 1\%$
- Current tolerances: $\pm 2\%$
- Frequency tolerances: $\pm 0.5\%$
- Power tolerances: $\pm 3\%$
- Time tolerances: $\pm 1\%$
- Temperature tolerances: $\pm 2\text{degC}$

10.3 Production Graphs

The following sections illustrate the inverter production/derating in terms of ambient temperature, altitude and grid voltage.

10.3.1 High Temperature Derating Graph

When the ambient temperature is higher than 113°F (45°C), the inverter output power (P_n) will begin to derate, as shown in Figure 10-1:

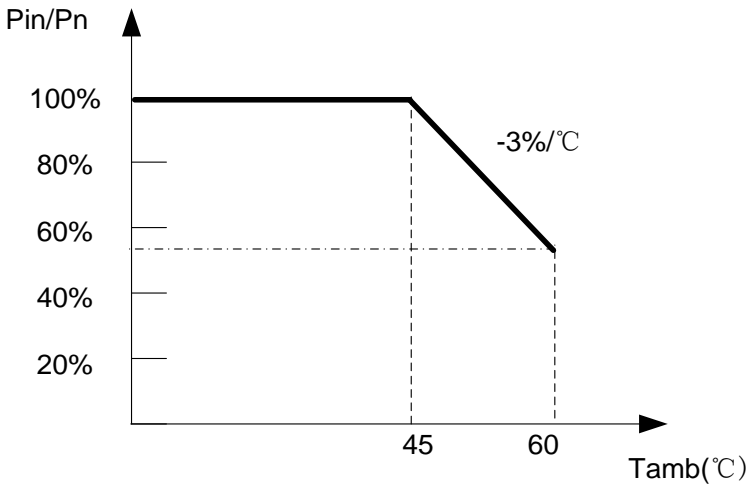

Figure 10-1 SCA25/50/60KTL-DO/US Derating Curve with High Temperature

10.3.2 Altitude Derating Graph

When the altitude is higher than 9842.5ft (3000m), the rated output power (P_n) of the inverter will decrease, as shown in Figure 10-2:

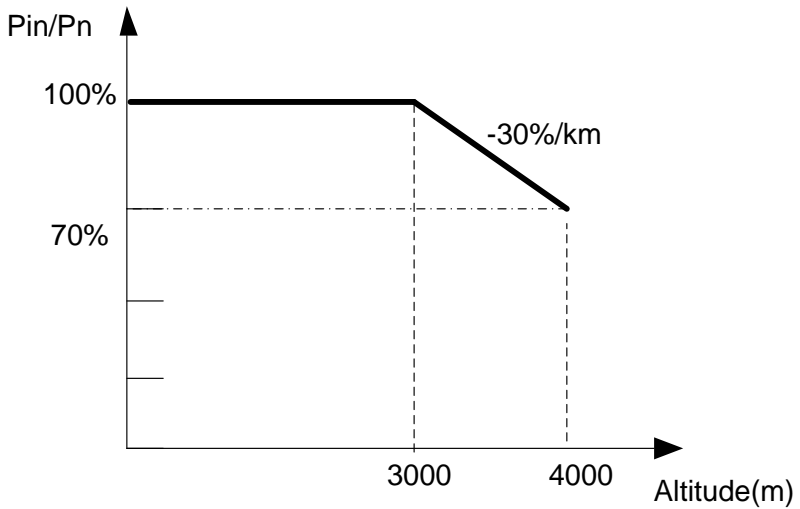

Figure 10-2 SCA25/50/60KTL-DO/US Derating Curve with High Altitude

10.3.3 Grid Voltage Derating Graph

1) When volt-watt function disable, the grid voltage is within 100%~110% ($U_n \sim 1.1*U_n$) of the Rated Output Voltage, the inverter output power (P_n) may reach 100%. When the grid voltage is lower than the Rated Output Voltage, the inverter will limit the AC Output Current and the output power (P_n) will begin to derate. shown in Figure 10-3-1.

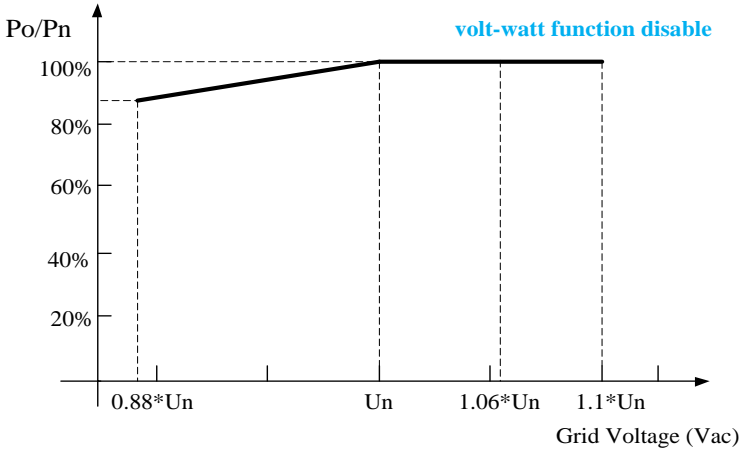

Figure 10-3-1 SCA25/50/60KTL-DO/US Derating Curve of Grid Voltage

2) When volt-watt function enable, the grid voltage is within 100%~106% ($U_n \sim 1.06*U_n$) of the Rated Output Voltage, the inverter output power (P_n) may reach 100%. When the grid voltage is lower than the Rated Output Voltage or more than 106% U_n , the inverter will limit the AC Output Current and the output power (P_n) will begin to derate, shown in Figure 10-3-2.

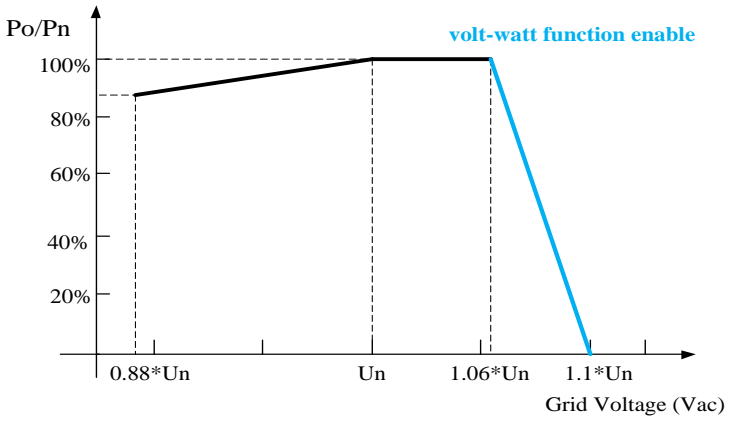

Figure 10-3-2 SCA25/50/60KTL-DO/US Derating Curve of Grid Voltage

10.3.4 Reactive Power Capability

The Reactive Power Overload function is disabled by factory default (Max. AC Apparent Power is 25/50/60kVA and Max. AC Output Current is 69.5/60.2A/72.2A). **Contact CPS Customer Service** if you want to enable the function.

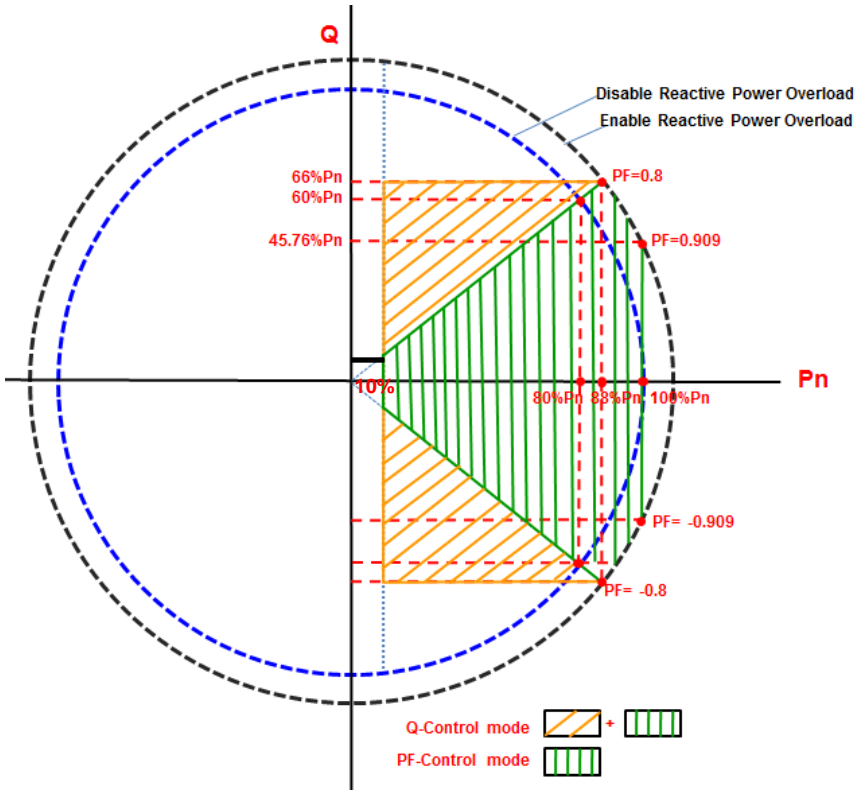

Figure 10-4 SCA25/50/60KTL-DO/US Reactive Power Capability



11 Limited Warranty

The warranty policy of this product is specified in the contract; otherwise, the standard warranty is 5 years.

For service, Chint Power Systems America will provide local support. For Warranty terms, please refer to the CPS America standard warranty policy in place at time of purchase.

CHINT POWER SYSTEMS AMERICA CO., LTD.

Address: 1110 E. Collins Blvd., Suite 106

Richardson, Texas 75081

Service Hotline: 855-584-7168

Email: AmericaSales@chintpower.com

Website: www.chintpowersystem.com

SHANGHAI CHINT POWER SYSTEMS CO., LTD.

Headquarters: Building 4, No. 3255, Sixian Road,

Songjiang District, Shanghai, China

Tele: +86 -21 -3779 1222 -866300

Fax: +86 -21 -3779 1222 -866001

Part No: 9.0020.0334 C0

This manual is subject to change without prior notification. Copyright is reserved.

Duplication of any part of this issue is prohibited without written permission.